

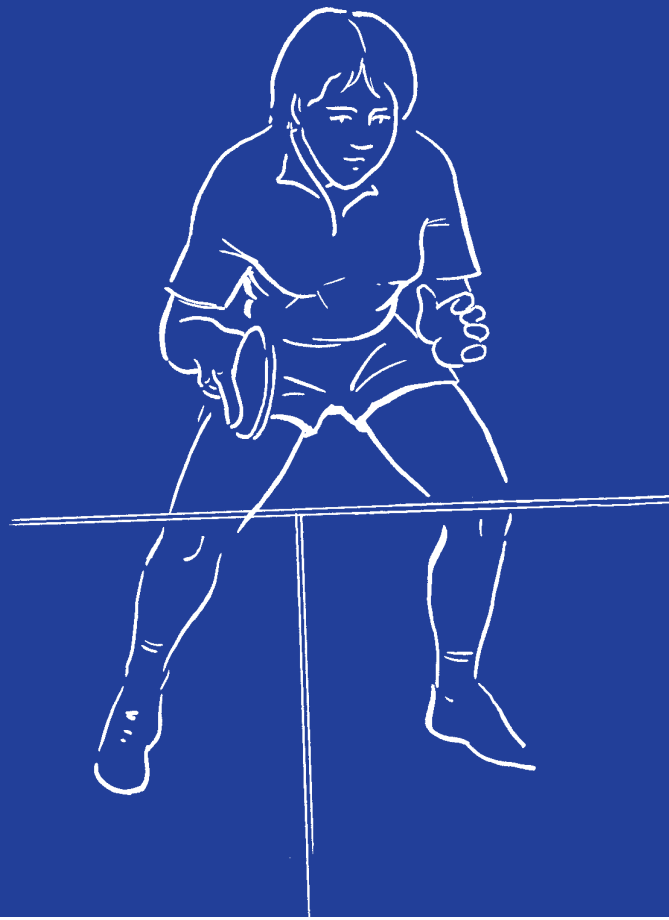

THE ROYAL MARINES

Table Tennis





Student Notes



Teacher Notes

Prepared for The Royal Navy in association with the English Table Tennis Association and English Schools' Table Tennis Association and produced by Education and Youth Limited, London.

If there is any support you feel the Royal Navy can give regarding this project please contact 0870 333 0423.

Acknowledgements

These notes have been compiled by the English Table Tennis Association and English Schools' Table Tennis Association, they include contributions from:

Gail McCulloch, ETTA Vice Chair – Coaching, Head of PE, Bishop Reindorp School, Guildford, Surrey.

Teresa Bennett, Sussex County No 1 player and former junior international, Head of PE, Filsham Valley School, Hastings, Sussex.

Tim Holder, ETTA National Team Psychologist, Sports Science Lecturer, Bishop Otter College of Higher Education, Chichester.

Diccon C Gray, ETTA National Development Manager.

Technical Editor: **P Edwards MA**

Thanks also to ITTF for permission to reproduce extracts from Table Tennis the Early Years and to Ron Crayden for historical assistance.

Document updated August 1999 by:

Peter A. Hirst ETTA Coaching Director,

with help from Ken Marchant and N.T. Houghton.

CONTENTS

	PAGE
INTRODUCTION TO THE MODULE	3
AN INTRODUCTION TO THE SPORT OF TABLE TENNIS	4
SKILLS DEVELOPMENT SHEET	5
UNIT 1 SCHEMES OF WORK	6
UNIT 2 SKILLS OF TABLE TENNIS	8
UNIT 3 TACTICS AND UNDERSTANDING OF TABLE TENNIS	16
UNIT 4 ASSESSMENT	20
UNIT 5 TABLE TENNIS, LAWS, EQUIPMENT AND OFFICIALS	21
UNIT 6 PHYSICAL CONDITIONING	26
UNIT 7 MENTAL PREPARATION	30
UNIT 8 HISTORY OF TABLE TENNIS	32
UNIT 9 THE STRUCTURE OF TABLE TENNIS	33
UNIT 10 CURRENT ISSUES IN TABLE TENNIS	34
UNIT 11 AWARD SCHEMES	36
USEFUL ADDRESSES	37
RECOMMENDED READING	37





Message from the Governing Bodies of Table Tennis

The English Table Tennis Association and English Schools' Table Tennis Association are working together to promote the development of Table Tennis. One of their aims is to provide a Youth Action Plan and this project will be part of that overall plan.

The aim of this module is to provide a valuable resource for teachers who are unfamiliar with Table Tennis. It provides guidelines which should enable teachers to fulfil the demands of the various examination boards.

The module should be considered as a sound basis for understanding and appreciating the skills, techniques and tactics required within the sport of Table Tennis.

The English Table Tennis Association and English Schools' Table Tennis Association are very grateful to the Royal Navy for producing this resource and hope that teachers find it both user-friendly and stimulating.

Introduction to the Module

Module Objectives

Students will:

- be able to understand, apply and appreciate the techniques, skills and tactics of the sport relevant to their ability level and within the context of the sport
- show an understanding of, and be able to apply the rules of the sport
- have an awareness of the structure of the sport at national and international level
- be able to interpret within the context of the sport the theoretical concepts which underlie all competitive sport.

Teachers will:

- be able to present the techniques, skills and tactics of the sport in a safe and educationally sound environment
- be able to assess student performance accurately and objectively
- be able to apply and officiate the rules of the sport as appropriate to the level of performance of their students
- have a clear understanding of the structure of the sport and a knowledge of where to obtain additional information
- be able to interpret the theoretical concepts which underlie all sport to increase their students understanding and appreciation of the sport of Table Tennis.





An Introduction to the Sport of Table Tennis

An Olympic sport since 1988, Table Tennis is fast becoming the largest indoor participation sport in the world.

A true “Sport For All”, Table Tennis is great for young and old, male or female, fit and not so fit, able-bodied and disabled. In fact, anyone can play Table Tennis.

It is easy to set up, relatively inexpensive and a healthy and safe activity, combining concentration of the mind with co-ordination of the body. And it's great fun!

As a school activity, Table Tennis can be particularly attractive for the following reasons:

- **excellent use of space** (4 tables on space equivalent to one badminton court – up to 16 players)
- **girls can play equally with or against boys**
- **not weather dependent**
- **versatile sport** (easy to set up, played in sports halls, gymnasias, dining rooms, classrooms, etc.)
- **early success rate for players** (basic skills can be easily learnt and pupils can gain early enjoyment)
- **table tennis support available** (large network of junior competitions and clubs to join. Advice on coaching, setting up a club, forming a team, applying for grants, etc.)
- **English Schools' Table Tennis Association** (competition network starting at local level)

Glossary of Terms

It should be noted that there are different ways of describing Table Tennis strokes. For example, the block may be referred to as the half-volley; backspin may be referred to as the slice, or called a basic push or an advanced chop; topspin may be called a basic drive or an advanced loop.

The descriptions provided in Unit 2 of this work provide clear definitions as used by the ETTA.

Within this text the following abbreviations/terminology are used:

F	- Forehand
B	- Backhand
FD	- Forehand Drive
BD	- Backhand Drive
FP	- Forehand Push
BP	- Backhand Push
TUS	- Technical Unit For Sport (Sports Council)
NVQ	- National Vocational Qualification
VQ	- Vocational Qualification
ITTF	- International Table Tennis Federation
ETTA	- English Table Tennis Association
Trajectory	- Flight path (e.g. of the ball)

Notes

1. All illustrations and explanations refer to a right handed player.
2. The tables have been illustrated as transparent to enable teachers to see the correct position of the feet.



Topspinner/Looper

Player who uses mainly top spin shots – close to the table.

Counter Hitter/Blocker

Player who uses mainly drive and block shots – very close to the table.

Chopper/Defender

Player who uses mainly back spin and defensive shots – away from the table.

Top Table

Competition using several tables where after an agreed time limit, winning players on each table move up one table and play a new opponent and losing players move down and play a new opponent.





Skills Development Sheet

The beginning stage of Table Tennis is the exploratory phase, where the player is attempting to learn the correct sequence of movements of all the basic skills e.g. service return, forehand drive. A number of errors may be made and players will need feedback to recognise and correct these errors. Initially a player may not be able to keep a rally going across the table and self-feeding may be necessary

During the intermediate stage the basic skills will be performed more consistently, and with more quality. Timing and anticipation will improve, although skills may break down under pressure of a game situation.

At the advanced stage all basic skills are automatic and are performed with quality. Players can concentrate on more detailed aspects of the skill and the tactics required.

Name of Module	Table Tennis
Basic Skills	The grip, ball control, service, return of service, backhand push, backhand drive, forehand push, forehand drive, block, loop chop (pages 8-15)
Game-play Skills	Consistency and patience. Good quality and variety of shorts. Good recovery (page 18)
Tactical Skills	Play to own strengths and opponents' weaknesses. Vary pace, spin, direction of ball. Variation on strokes. Anticipation (pages 16-19)
Training Skills	Muscular endurance, cardiovascular endurance, strength, flexibility (pages 20-29). Mental preparation (page 30)
Rules	Copies of the laws can be obtained from: English Table Tennis Association (ETTA) (see page 37 for address).





UNIT 1 Schemes of Work

1. The recommended scheme of work is both skills and games understanding based and is progressive, although the sessions may be mixed about according to the groups ability.
2. The scheme of work is for 12 lessons, progressing from a base of no previous knowledge. The scheme may be modified to suit the particular needs of any school.
3. The laws of Table Tennis covering play should be introduced in a logical sequence each session. (See Table 1.1.)

Sample Lesson Plans

6 weeks x 2 lessons

Time	5 mins	5 mins	10/15 minutes	10/15 minutes	5 mins	5 mins	
Week 1	1	Setting up equipment	Warm-ups, use balls in initial lessons	Safety of equipment – storage. Basic bat control. Technique for backhand push.	Competition/games – round the table, longest rallies	Cool down and verbal recap of lesson	Putting away equipment
	2			Revise backhand push – develop accuracy to targets.	Competition with emphasis on targets. Top table		
Week 2	1			Technique for forehand drive. Basic backhand push service.	Basic game with backhand push service (up to 7 points)		
	2			Knock up using backhand push and forehand drive. Recap forehand with movement (footwork).	Competition for longest rallies (backhand and forehand). Game (up to 7 points)		
Week 3	1			Knock up. Forehand topspin services to various targets. Recap backhand service.	Game (up to 11 points) top table – specify type of service		
	2			Knock up. Technique for backhand drive.	Game. Tactics for singles. Scoring (up to 21 points)		
Week 4	1			Knock up. Recap backhand drive. Combination of backhand and forehand drive with movement (footwork).	Game. Singles – continue looking at basic tactics		
	2			Knock up. Recap services – long and short topspin and backhand push and return of service.	Game. Tactics for doubles, laws, positioning		
Week 5	1			Knock up. Combination of backhand push and forehand drive on same line to incorporate movement (footwork).	Game. Doubles – further look at tactics (up to 21 points)		
	2			Knock up. Technique of forehand push – to targets or combined with backhand if able.	Game – Using forehand backspin serve		
Week 6	1			Knock up. Recap of all strokes. Practice as necessary for assessment.	Game. Singles and doubles		
	2			Knock up. Assessment (this may be done over several lessons).			

Table 1.1

FUN GAMES

In the early stages of learning Table Tennis, or as an introduction to a skills or tactics session, fun games can serve in the development of skill, as part of a warm-up or simply as some light relief in an otherwise intense session. The following are examples of the type of fun activity which can be used. Staff are, however, encouraged to improvise and develop their own versions of such activities.

1. Overtaking

Player sprints round the outside of the playing area with the ball balancing on the bat. If overtaken, or the ball is dropped, player drops out. Continue until only one player is left.

Variations:

- bouncing the ball on backhand or forehand or alternating between the two.

2. Minute Rally

Two players per team.

The total number of strokes achieved by the two players in one minute.

3. Round the Table

Players line up in the same number at each end of the table. A particular stroke is selected – e.g. forehand drive. Each player plays one stroke then runs round the table to join the end of the line on the opposite side.

Player drops out of the activity if three mistakes are made.





4. Team Singles

Two teams with a minimum of two players each.

Two players, one from each team, play a point. The losing player drops out of the activity to be replaced by the next member of the team.

Variations for small teams – play a series of five points or similar variations to decide the winner.

5. Football

Two players per team

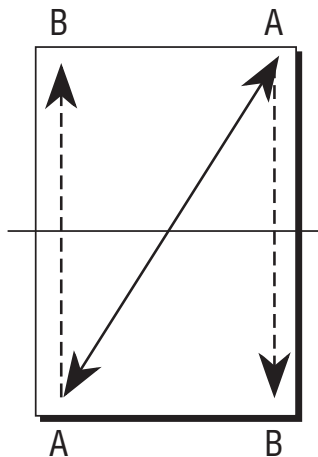

Figure 1.1

Team A play the ball to each other along the diagonal. Either member of team A hits the ball, at random, down the line to a team B player. If the team B player fails to return the ball, then team A scores a goal.

6. Badminton

Points won count only when the player is serving. If the point is lost, service reverts to the opponent.

7. Golf

Player serves towards target placed on the table or serves in an attempt to land the ball in a bucket placed on the floor.

8. Cricket

Two teams with a minimum of three players each.

The bowler throws the ball, underarm, from behind the end line of the table so the first bounce is on the opposite side of the table. The height of the throw should be around head height.

A run is scored when the batsman hits the ball so that it bounces on the opposite side of the table and then on the floor.

Four runs are scored if the ball hits a wall directly after bouncing on the opposite side of the table.

A wicket is taken if:

- the batsman misses the ball
- the batsman hits the ball into the net
- the batsman hits the ball off the end of the table
- a fielder catches the ball before it hits a wall or the floor

9. Relays – see Figure 1.2

a)

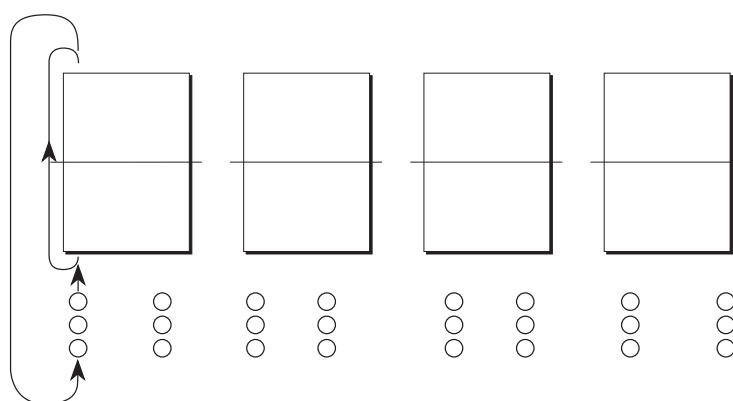

Figure 1.2

The player runs to the table and serves, then runs around the table and catches the ball after one bounce and before it hits the floor. If successful, the player scores a point. The player then returns to the team line with the ball. Next team member repeats the activity. The first team to score 10 points is the winner.

Variations – repeat but with two bounces on the table, or to a specific target area marked on the table.

b)

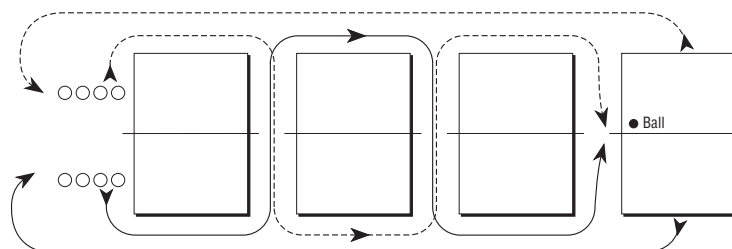

Figure 1.3

Two players, each carrying a bat, run around the tables, as indicated in Figure 1.3 above, to the last table. The player in the lead picks up the ball from under the net and serves. The opponent then attempts to return the ball. As soon as the point is over, the ball is replaced as indicated in Figure 1.3 and both players return to the team line. The next team players then repeat the activity.

Variations:

- Players run without bats which are placed, with the ball, on the table.
- Players run with the ball balanced on the bat. The first to arrive at the last table then serves.
- As above, but bouncing the ball on the bat.

10. Throwing

Play a game by throwing the ball into the receiver's court. The receiver catches and throws back.





UNIT 2

Skills of Table Tennis

The techniques and skills of any sport are the vocabulary the player will use in implementing the tactics of the sport. While it is vital that players acquire as broad a range of skills as possible, it is important to remember that skills should be developed in realistic contexts, i.e. similar to those in which they will be applied in the game. Additionally, staff should remember that there is no **one** way to acquire a skilful outcome, and should always take into account individual differences when teaching skills.

GRIP

The grip favoured by most players in the Western world is known as the “shake hands” grip. Although there are alternatives, notably the “penhold” types used predominantly in the Far East (e.g. China and Japan), these will not be discussed here.

TASK - The purpose of the grip is to control the angle of the bat.

WHY? - The angle of the bat controls the:

- Height of the ball
- Depth of the ball
- Speed of the ball
- Type of spin
- Amount of spin
- Direction of the ball

HOW? - With the shake hands grip, the bat handle is held in the palm of the hand such that the start of the bat head fits snugly into the “V” shape formed by the thumb and the first finger. Each of these digits should lie roughly parallel with the straight edge of the rubber at the base of the bat head. In this position, they provide fine control over bat angle.

- Movement of the thumb and/or first finger to positions towards the centre of the bat head should be avoided, otherwise fine control will be diminished and there will be significant risk of impeding the ball. The remaining three fingers are wrapped round the handle to provide bat stability. The grip should be firm but not tight and the bat should form a near linear extension of the hand and forearm. The forehand and backhand grips are illustrated in Figure 2.1.

WHEN - All the time during play.

TEACHING TIPS

- Ensure that the thumb and forefinger lay flat in the blade of the bat.
- The three remaining fingers should be loose around the handle.

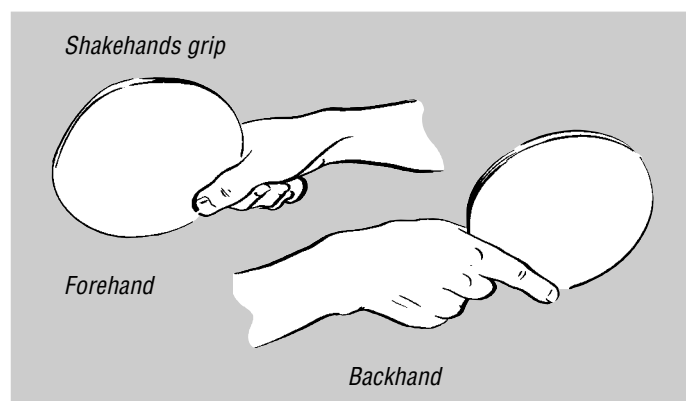

Figure 2.1

BAT (RACKET) ANGLES

The following are recommended as the optimum angles for specific shots (see Figs 2.2a,2b,2c).

- With the bat held such that the head is in a vertical position, the angle is described as neutral.
- With the striking surface angled downwards, the angle is described as closed.
- With the striking surface angled upwards, the angle is described as open.

The angle is varied by rotating the hand and forearm.

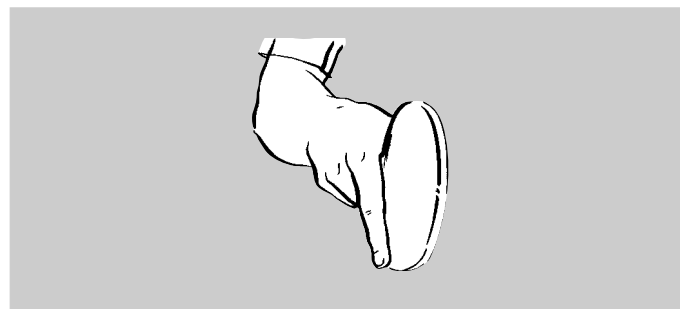

Figure 2.2a: Neutral

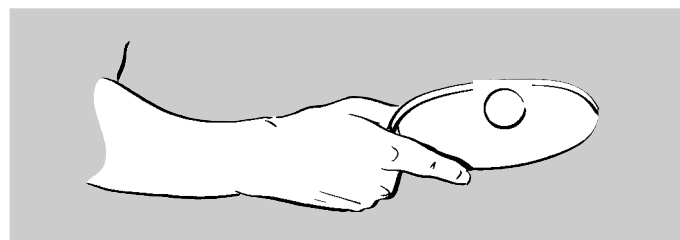

Figure 2.2b: Closed

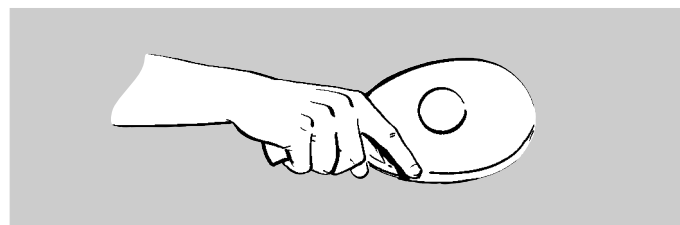

Figure 2.2c: Open

Although there are other factors, a closed bat angle will produce topspin (rotation of the ball away from the player) whilst an open bat angle will produce backspin (rotation of the ball towards the player). For further details see the section on Spin.





BASIC BALL CONTROL

At the beginner stage, ball control may not be good enough to allow reasonable stroke play. This could be a particular problem with young children where hand/eye co-ordination may not be well developed. Significant improvement in ball control, coupled with an understanding of touch, can be achieved off the table using the following exercises:

1. Bouncing the ball on the forehand side of the bat, attempting to achieve a uniform height.
2. As 1 but using the backhand side of the bat.
3. Bouncing the ball each side of the bat alternately.
4. Repeating exercises 1, 2 and 3 but varying the height of the bounce.
5. Repeating all exercises but with added movement such as walking or light jogging.

Success and improvements with these exercises will be best achieved if the angle of the elbow is around 90 degrees and reasonable space is maintained between the elbow and the body. Basic ball skills and touch can be further developed through the use of fun games. See Unit One.

Backhand Push

TASK - To make the ball bounce twice on the receiver's side. The second bounce to be on or near the receiver's base line with a trace of backspin.

WHY? - To keep the ball safe from the opponent attacking the ball. To increase the opportunity to attack.

HOW?

Stance	Facing the line of play
Table Position	Close
Length of Swing	Short with 50% before contact 50% after
Timing	Top of the bounce
Body Movement	Nil
Bat Arm Movement	Moves from the elbow in an horizontal plane
Free Arm	Points to ball acting as a reference point.

WHEN - The approaching ball is likely to bounce twice.

TEACHING TIPS

- Strike the back bottom part of the ball with a very light touch.

Forehand Drive

TASK - 100 mph
Close to the base or a side line with a trace of topspin.

WHY? - To decrease the amount of time available to the opponent.

HOW?

Stance	Side to facing the line of play
Table Position	Close
Length of Swing	Medium with 50% before contact and 50% after
Timing	Top of the bounce
Body Movement	Upper body rotates approx. 45 degrees to the right, turning back to face the ball. The body weight moves from the right foot to the left on production.
Bat Arm Movement	The bat moves forward and slightly upward in the direction that the ball is to travel. The bat angle is slightly closed

Free Arm

Points to the ball as a reference
point, assisting with the body turn
and balance

WHEN? - The approaching ball has either height and/or depth.

TEACHING TIPS

- Strike the top back part of the ball with a forceful brush in an upward direction.
- Place the forefinger of the free hand on the playing wrist to aid the feeling of the upper body rotation.

Backhand Drive

TASK - 100mph
Close to the base or a side line with a trace of topspin

WHY? - To decrease the amount of time available to the opponent.

HOW?

Stance	Facing the line of play
Table Position	Close
Length of Swing	Medium with 50% before contact and 50% after
Timing	Top of the bounce
Body Movement	Nil
Bat Arm Movement	The bat moves forward and slightly upward in the direction that the ball is to travel. The bat angle is slightly closed. The elbow produces the forward movement with a loose wrist the topspin aspect
Free Arm	Points to the ball as a reference point.

TEACHING TIPS

- The action is similar to that of throwing a Frisbee. Striking the top back part of the ball with a forceful brushing action.

Forehand Push

TASK - To make the ball bounce twice on the receiver's side. The second bounce to be on or near the receiver's base line. With a trace of backspin.

WHY? - To keep the ball safe from the opponent attacking the ball. To increase the opportunity to attack.

HOW?

Stance	Facing the line of play
Table Position	Close
Length of swing	Short with 50% before contact 50% after
Timing	Top of the bounce
Body Movement	As a reduced version of the forehand drive
Bat Arm Movement	Moves from the elbow in an horizontal plane
Free Arm	Points to ball acting as a reference point. Assisting with the body and balance

WHEN? - The approaching ball is likely to bounce twice.

TEACHING TIPS

- Strike the back bottom part of the ball with a very light touch.
- The ball should have a trace of backspin.





BASIC STROKES

There are four basic strokes from which all of the more advanced techniques are developed (see Figure 2.3):

- Backhand Push: the basis for backhand backspin
- Forehand Drive: the basis for forehand topspin
- Backhand Drive: the basis for backhand topspin
- Forehand Push: the basis for forehand backspin

Figure 2.3

The Order of Teaching Basic Strokes

It is generally thought that if a player learns the forehand drive as their first stroke, they are more likely to adopt an attacking attitude towards the game. However, for this to be successful, the player needs to have a good consistent "feed" ball and this is not always possible in schools. It is, therefore, often more practical for the backhand push to be the first stroke taught as this is technically the easiest stroke. The forehand drive is normally the second stroke to be introduced. The backhand drive is the third stroke to be taught as this is a progression from the backhand push. The forehand push – technically the hardest – is the last of the four basic strokes to be taught.

SERVICE

As the stroke which starts every rally, service can be regarded as the most important stroke in Table Tennis since it provides the only situation in which the player has total control over how and where to play the ball. The following will help explain the basics of service.

The player should:

1. Be positioned initially down the side of the table at a point midway between the end of the table and the net. Use a normal grip for backhand with the bat held stationary and at an open angle. Hold the ball between the thumb and the first finger of the free hand at a height of around 30cm directly above the bat. (See Figure 2.4.)

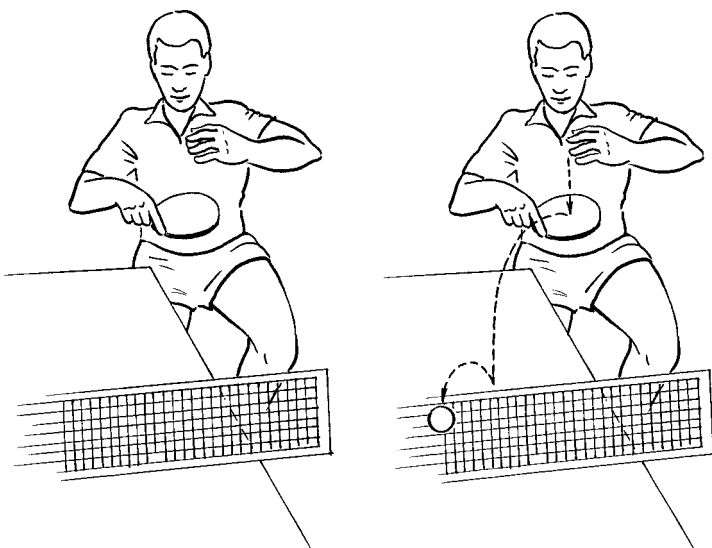

Figure 2.4

2. Drop the ball onto the bat. The ball should be projected forwards and upwards. The first bounce should be on the player's side of the table such that the ball clears the net and then bounces on the opponent's side.

Once this has been successfully carried out, progressively move the player's position to points nearer to the end of the table and, finally, to a point behind the end of the table. Repeat 1 in each case but introduce sufficient movement of the bat arm to achieve the result shown in Figure 2.4.

At this stage, introduce throwing the ball up, as near vertically as possible, from the palm of the free hand. Allow the ball to drop before making contact with the bat. If the outcome satisfies the result shown in Figure 2.4, then an acceptable service has been achieved.

Service Return

Service return can be regarded as the second most important stroke in Table Tennis since this is the first opportunity, in any rally, for the receiver to play the ball.

At basic level, depending upon the length of the service, the receiver should return the ball in one of two ways:

- Push (from a short service)
- Drive (from a long service)

In preparing to return the service, the position taken up by the receiver will be dictated by the position taken up by the server. The principle is identical to that for "Recovery" (see Unit Three) but, in this case, the position is known as the ready position. (See Figure 2.5.)

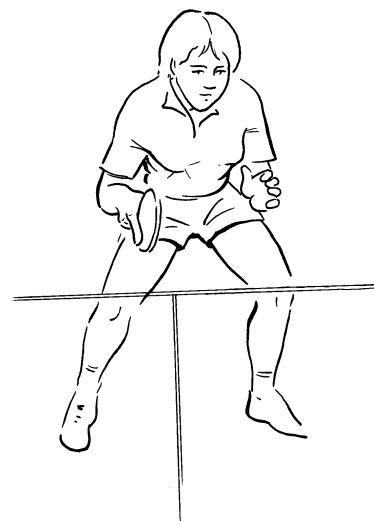

Figure 2.5

The receiver should vary the direction of the return by making good use of the available angles and lines of play.

NOTE

The crossover point is the area in which the player has no obvious choice of forehand or backhand. For a right handed player, the crossover point is roughly in line with the right hip.





Spin

Spin plays a vital part in Table Tennis. The ball is generally struck with either topspin or backspin. In addition, sidespin may be added.

Topspin

Topspin is produced by starting the stroke below and/or behind the ball and contacting the ball as lightly as possible, i.e. brushing the ball in an upward and forward motion. (See Figure 2.6.)

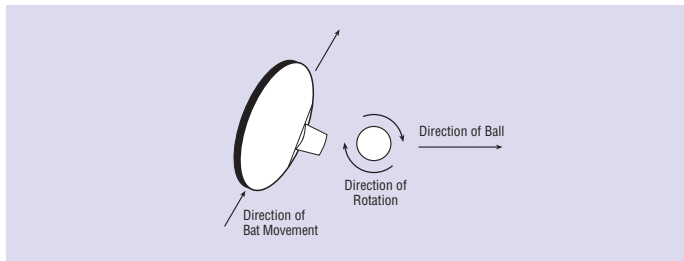

Figure 2.6

Backspin

Backspin is produced by starting the stroke above and/or behind the ball and contacting the ball as lightly as possible, i.e. brushing the ball in a downward and forward motion. (See Figure 2.7.)

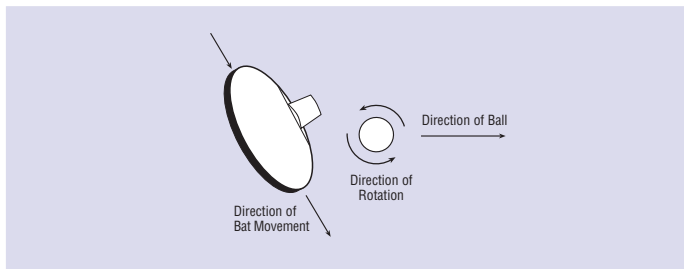

Figure 2.7

Sidespin – view from above the ball.

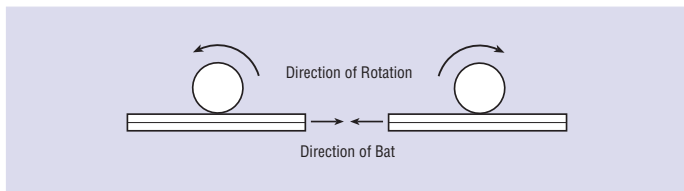

Figure 2.8

The Effect of Spin – on the trajectory of the ball

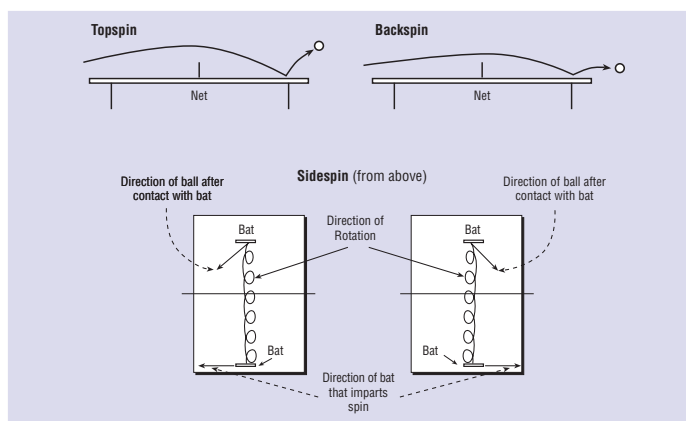

Figure 2.9

The use of excessive spin is particularly effective in the service.

STROKE VARIATION AND ADVANCED TECHNIQUES

As players improve, it is necessary to challenge and extend them beyond the basic skills to the more advanced skills and techniques. Again, in doing this, it is necessary to remember that individual differences will play an important part in both the learning and performance of these skills. It is also important to remember that, at this stage, staff should be encouraging students to develop variety in their strokes because stereotyped skills are easy for opponents to read.

Spin Practice

- Using forehand side of the bat bounce the ball vertically imparting sidespin as a result of a loose wrist action
- As above with the opposite sidespin
- As above with alternate spin

Teaching Tips

- The ball should bounce as near to vertical as possible
- A wrist action should produce most of the movement as opposed to the elbow
- Use a light degree of touch

The Block

TASK - Is to angle the ball away from the receiver. Usually near to the base or side lines.

WHY? - To catch the opponent out of position. Reduce the time available to the receiver.

HOW? Stance	Facing the line of play
Table Position	Close
Length of Swing	Short with 50% before contact 50% after
Timing	As the ball is rising
Body Movement	Nil
Bat Arm Movement	Moves from the elbow in an horizontal plane
Free Arm	Points to ball acting as a reference point. Assisting with the body rotation and balance

WHEN? - The approaching ball is moving very quickly and with topspin. The block strokes are best used when a player has very limited time available. 50% of the stroke should be before contact and 50% after to keep the receiver guessing as to what nature of stroke will be played.

TEACHING TIPS

- Use a light degree of touch.

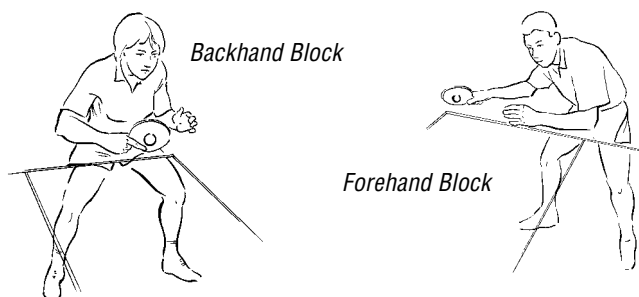

Figure 2.10





The Loop

TASK - Maximum topspin, with as much speed as possible. Play deep and/or angled.

WHY? - To reduce the control level of the opponent. Increase the pressure on the opponent.

HOW?

Stance	Facing the line of play for backhand. Side to facing for forehand
Table Position	Close
Length of Swing	Medium with 50% before contact 50% after
Timing	Variable
Body Movement	Accentuate the movement by pushing strongly with the legs
Bat Arm Movement	Use all three joints of the playing arm to gain maximum spin
Free Arm	Points to ball acting as a reference point. Assisting with the body rotation and balance

WHEN? - The approaching ball is long and/or high enough. At the earliest opportunity.

TEACHING TIPS

- Practice against balls which have been repeatedly rolled along the table striking as early as possible when the ball drops off the end.
- Use a medium degree of touch with a fast brushing action.
- Vary the speed of the rolling ball.
- Use a loose grip.

The Chop

TASK - Maximum backspin. Place as short or as long/wide as possible.

WHY? - To reduce the control level of the opponent.

HOW?

Stance	Facing the line of play for backhand. Side to facing the forehand
Table position	Variable
Length of Swing	Medium with 50% before contact and 50% after
Timing	Variable
Body Movement	Accentuate the movement by pushing strongly with the legs
Bat Arm Movement	Use primarily the elbow and wrist joints of the playing arm to gain maximum control and spin
Free Arm	Points to the ball as a reference point. Assisting with the body rotation and balance

WHEN? - The approaching ball is short or very deep and fast. At any time.

TEACHING TIPS

- Use a medium degree of touch with a fast brushing action.
- Use a loose grip.
- Keep the playing wrist loose.

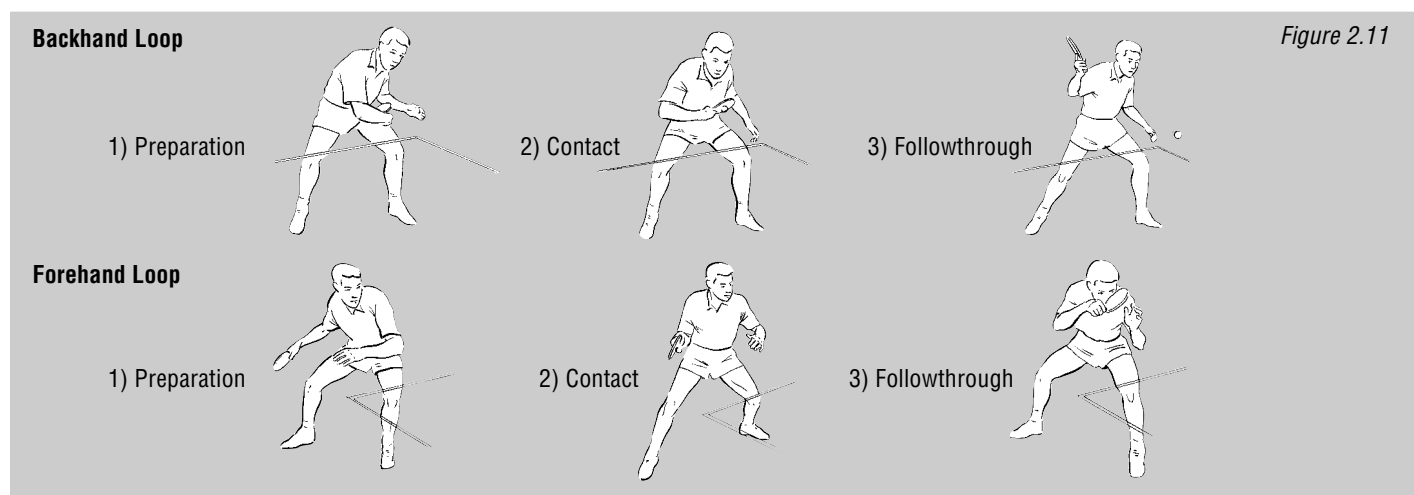

Figure 2.11

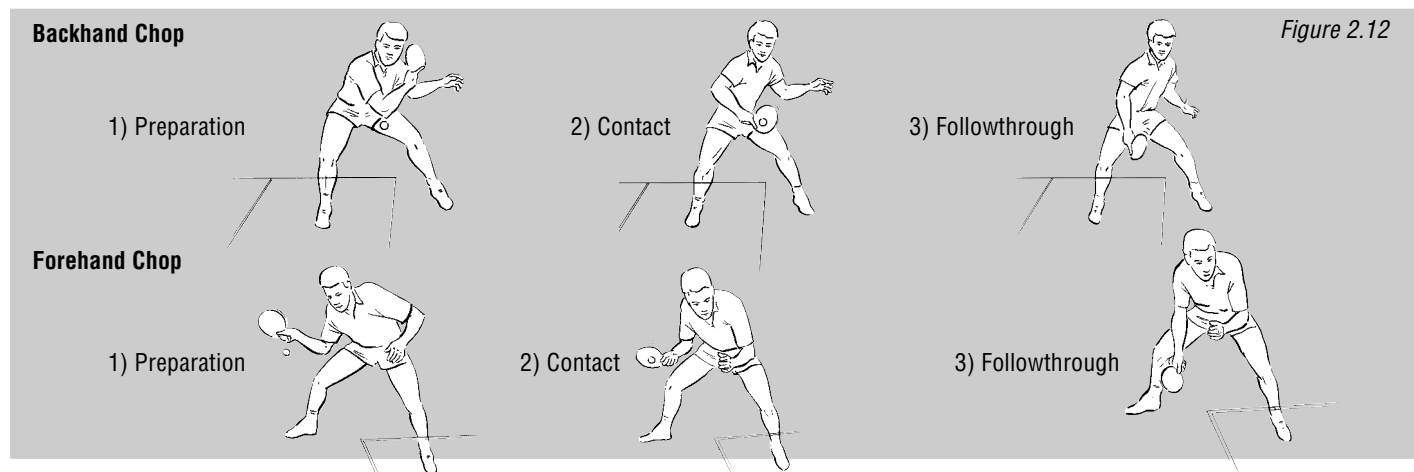

Figure 2.12





ADVANCED SERVICE AND SERVICE RETURN

Once a basic short and long service has been established on both the forehand and the backhand, the player may look for a greater variety of services to improve his/her game, by varying the spin, speed, disguise and direction of the ball. For advanced service technique the wrist becomes of paramount importance.

1. Short Backspin Service

TASK - Apply backspin. Two bounces on the receiver's side. Keep the ball low.

WHY? - To limit the receiver's chances of attacking the ball. To increase the chances of the server getting a ball long enough to attack.

HOW?

Stance	Facing and low
Table Position	Close
Length of Swing	Short as possible to disguise the stroke
Timing	Strike on descent
Body Action	Minimum to aid disguise
Bat Arm	Relaxed and fast wrist action
Free Arm	Releases the ball

WHEN? - When servers wants to stop the receiver from attacking.

TEACHING TIPS

- Medium degree of touch with a fast action.
- Bounce on the server's side must be near the net.
- 2nd bounce on receiver's side must be close to the base line.
- Strike the bottom/back part of the ball.

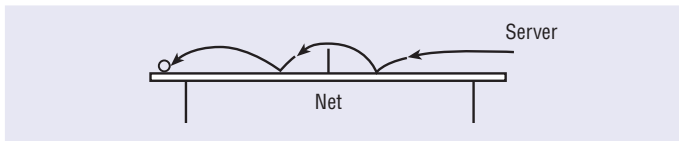

Figure 2.13

This type of service should be encouraged since it makes it difficult for the receiver to play an attacking stroke.

Significant progress can be made in developing service by using multi-ball practice in which several balls are available with which the server can practice alone.

2. Backhand Sidespin Service

TASK - Apply sidespin. Two bounces on the receiver's side. Keep the ball low.

WHY? - To limit the receiver's chances of attacking the ball. To increase the chances of the server getting a ball long enough to attack. To limit the receiver's range of stroke. To encourage receiver to return the ball to specific area e.g. to server's forehand.

HOW?

Stance	Facing and low
Table Position	Close
Length of Swing	Short as possible to disguise the stroke
Timing	Strike on descent
Body Action	Minimum to aid disguise
Bat Arm	Relaxed and fast wrist action
Free Arm	Releases ball

WHEN? - When server wants to stop the receiver from attacking.

TEACHING TIPS

- Medium degree of touch with a fast action.
- Bounce on the server's side must be near the net.
- 2nd bounce on receiver's side must be close to the base line.
- Strike the back/middle part of the ball.

Backhand Sidespin Service

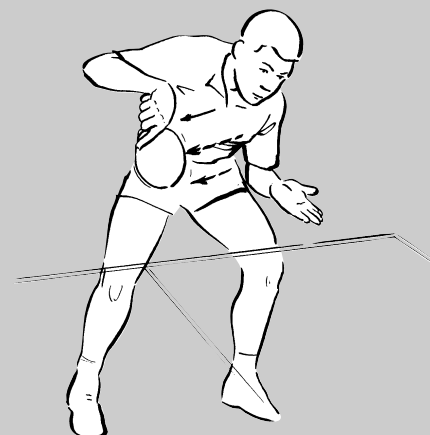
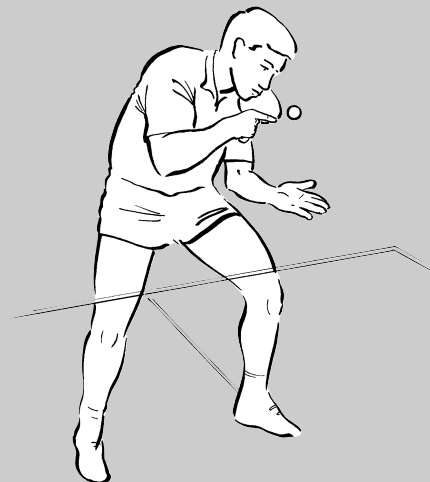
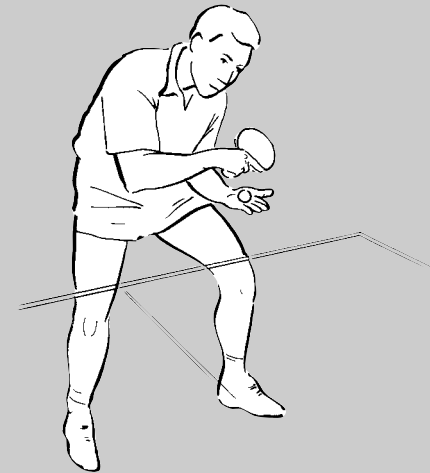

Figure 2.14





3. High Toss Service

Favoured by many top players, originally established by the Asian players, to convert the accelerating descent of the ball into spin and speed. The service can be distracting and it is possible for the free arm to shield the contact point of bat and ball making it very difficult for opponents to read the spin.

4. Forehand High Toss Service from Backhand Court

TASK - Apply sidespin and/or topspin/backspin. Two bounces on the receiver's side. Keep the ball low.

WHY? - To limit the receiver's chances of attacking the ball. To increase the chances of the server getting a ball long/high enough to attack. To limit receiver's range of stroke. To encourage receiver to return the ball to specific area e.g. to server's forehand to make service difficult to read.

HOW?

Stance	Sideways at the B corner of the table
Table Position	Close
Length of Swing	Short as possible to disguise the stroke
Timing	Strike on descent
Body Action	Minimum to aid disguise
Bat Arm	Relaxed and fast wrist action
Free Arm	Releases ball and shields bat for deception

WHEN? - Server wants to stop the receiver from attacking. Server wants to attack the return.

TEACHING TIPS

- The grip should be relatively relaxed to allow use of the wrist.
- To produce a bounce which is consistent with a low trajectory over the net, the contact point should be around 15cm higher than the surface of the table (about the same height as the net).
- The service should be varied in length, speed and direction.
- A long fast service may be produced using a slightly closed bat angle. The ball should make contact with the table within the first third of the server's half.
- A short, relatively slow service may be produced using an open bat angle. The ball should make contact with the table around two thirds of the way down the server's half.
- A particularly effective short service is one in which the second bounce on the receiver's side (if the ball is not played) makes contact with the table at or very near the end of the table. (See Figure.2.13.)

Figure 2.15

Forehand High Toss Service

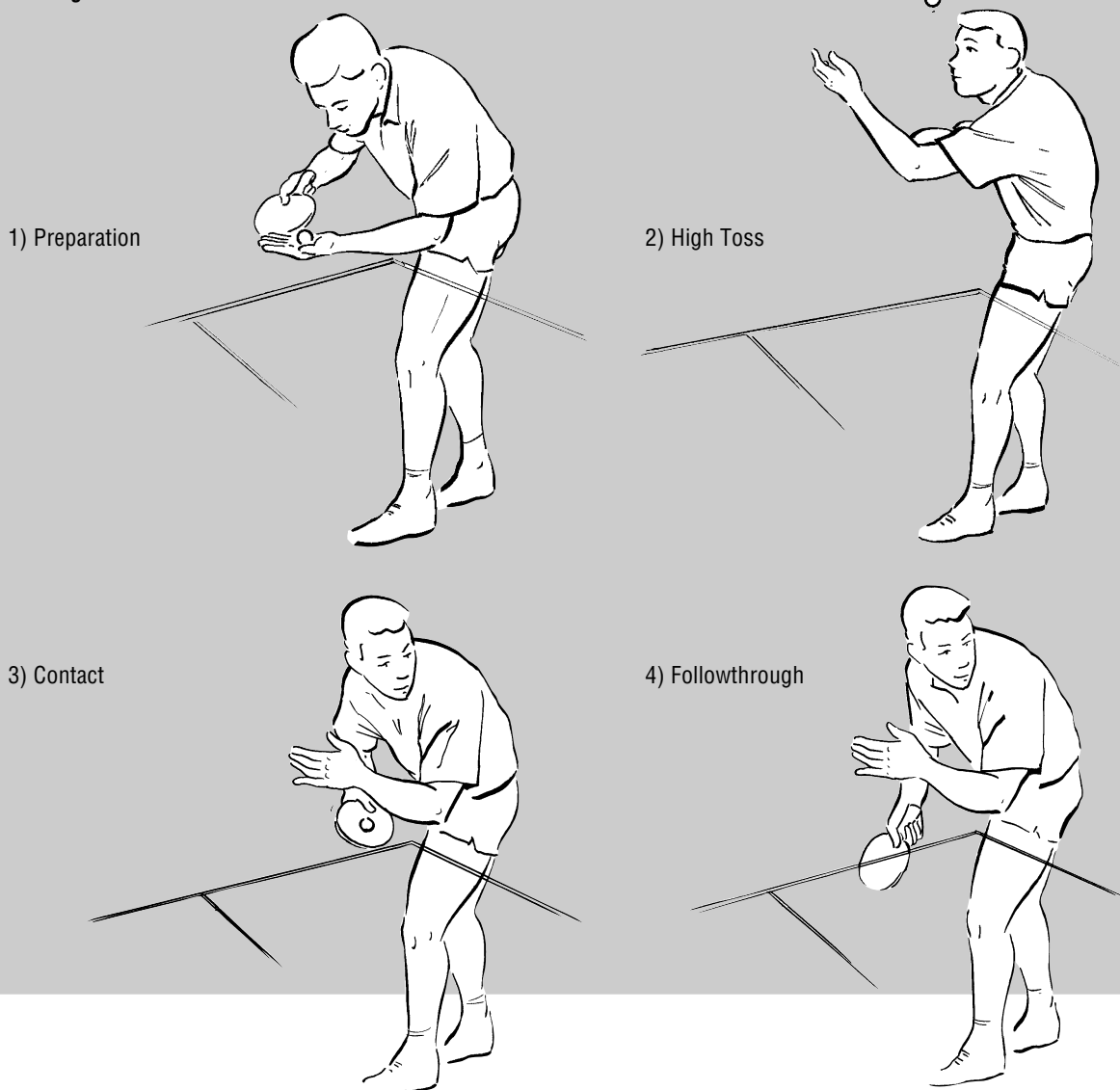



ADVANCED RETURN OF SERVICE

Once a basic push and drive stroke has been established to return service, it is possible to consider a variety of positive returns. The three which are favoured by most leading players to return a short service are:

1. Short Push

TASK - Return the ball with at least 2 bounces. Return the ball to a wide angle. Return the ball low.

WHY? - To make it difficult for the server to attack the ball.

HOW?

Stance	Low, wide, eyes level with the ball
Table Position	Well over the table
Length of Swing	Short
Timing	Early as possible, before peak of the bounce
Body Action	Lean over the table
Free Arm	Assists with balance. Points to the ball acting as a reference point

2. Fast Attacking Push

As above but use fast wrist action to push it deep and fast. Aim into cross over point (see Figure 2.5) or play it wide.

3. Flick

As above, but change from an open to a closed bat, hit over the back or top of ball, using wrist. (See Figure 2.16.)

APPLICATION OF STROKES WITHIN THE GAME

It is important to remember that the only purpose of techniques and skills is to enable the player to apply them effectively and efficiently within the game. While there is never only one standard application, the following provide examples of when a player may use a specific stroke. (See Table 2.2.)

STROKE	EXAMPLES OF WHEN TO USE
Backhand push	Returning short services
Forehand drive	Returning long services Against a long pushed ball
Backhand drive	Returning topspin in a rally Returning topspin services
Forehand push	To bring a defensive player close to the table Returning short balls
Block	Reacting quickly to topspin
Loop	Returning chopped balls Attacking long, pushed balls
Chop	Away from the table against topspin

Table 2.2

Forehand Flick

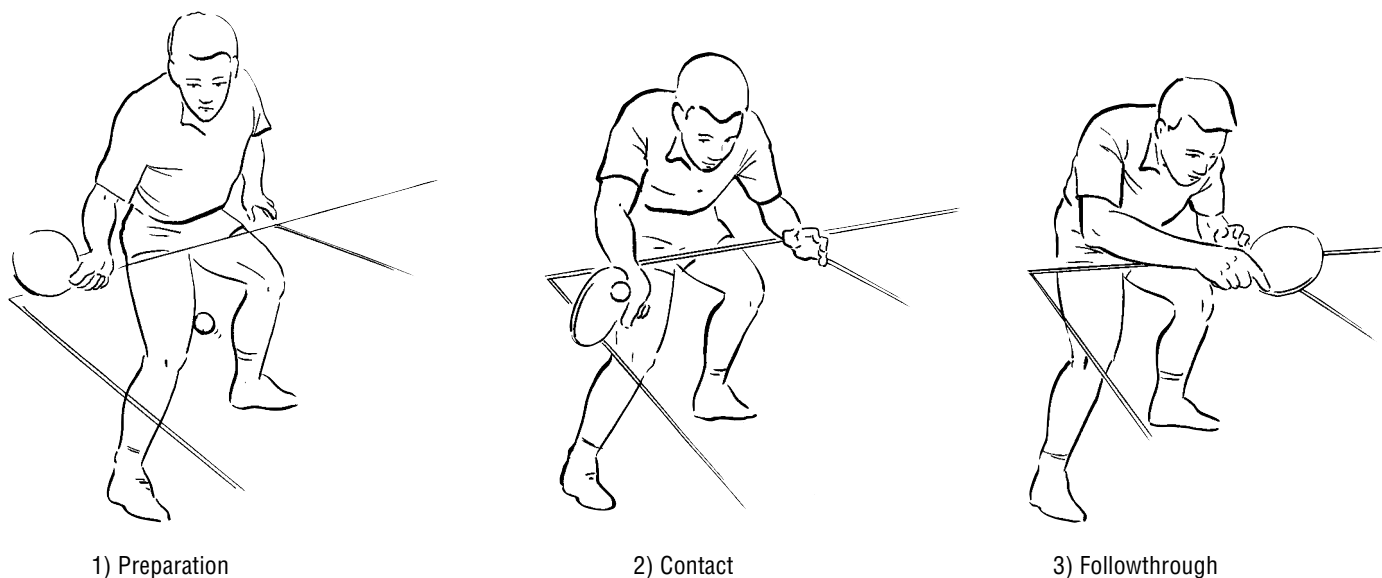

Figure 2.16





UNIT 3

Tactics and Understanding of Table Tennis

The aim of the game is to send and return the ball over the net onto the table one more time than the opponent. It is not possible to cover complicated tactics in any detail, and teachers are referred to more comprehensive texts. (See Recommended Reading.) The first part of this section is concerned with the singles game, and the latter part with doubles.

In terms of tasks this section has been subdivided into key points. See Table 3.1.

Generally there are 3 stages of Tactical Development:

1. To get the ball on the table.
2. The accuracy to get the ball to certain areas of the table.
3. The ability to apply pressure to areas of the table and the opponent with different types of spin, amounts of spin and different speeds to create openings to hit winners.

NOTE

A favourite tactic would be to apply pressure to the cross-over point which is the area in which there is no obvious choice of a forehand or backhand stroke. For a right handed player this cross-over point is roughly in line with the right hip.

TACTICS TO USE TO PLAY EFFECTIVE TABLE TENNIS

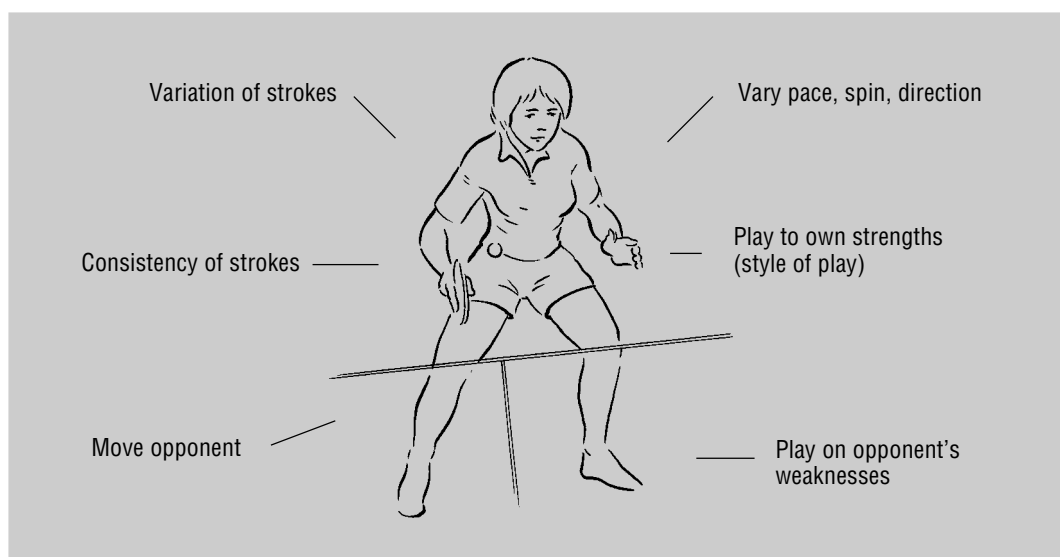

Table 3.1

Recovery

Recovery is the process which joins the various strokes together. The point to which the player has struck the ball determines the opponent's options for the return. The two extreme options indicate the player's recovery position. (See Figure 3.2.)

Essentially, the player should recover to a position which is approximately square to a line which divides the angle between the two extreme options (see Figure 3.2 position R). In the case of a right handed player, the right foot should be on or around this dividing line.

Recovery to the position described is fundamental to the player's ability to subsequently cover, with relative ease, the options available to the opponent. It is vital that the player is taught to start and finish all strokes with the bat in the recovery position.

It is vital that players are taught to regard recovery positions at both the start and finish point of all strokes and movement patterns and that these positions are decided by the position of the target selected by the player.

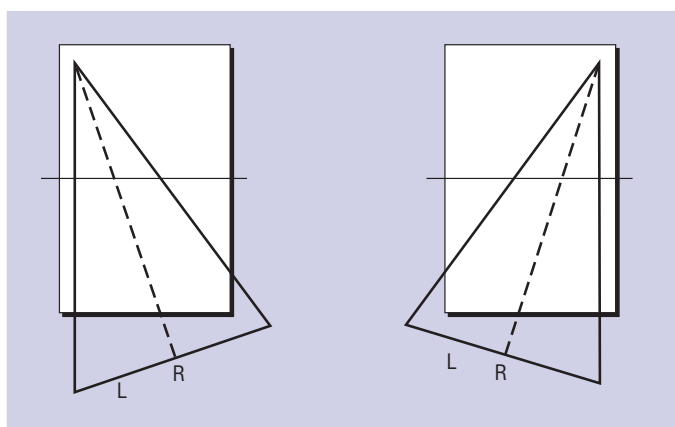
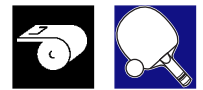

Figure 3.2 L = left foot R = right foot



Anticipation

In any situation which involves an irregular pattern, the time available to prepare to play an opponent's return is not long. This is particularly true if the player simply reacts to the movement of the ball after it has been struck by the opponent.

Anticipation of the direction of ball travel and the type of stroke to be played by the opponent will maximise the time available for preparation. In addition to always watching the ball, the player should try to anticipate the opponent's intentions by specifically watching the bat and bat arm.

There are other considerations such as knowledge of the opponent's game, particularly in terms of strengths and weaknesses.

Irregular movement patterns designed to develop anticipation should be introduced into table exercises as soon as stroke play and regular movement combinations are reasonably proficient. The following are examples of how staff might further explain and exemplify the tactics of the game.

Example 1

- TACTIC** - Play on opponent's weakness.
- WHAT?** - What is his/her major weakness and how may this be exploited?
- HOW?** - By placing the ball around the table to find the weak spot.
- TASK** - Work in twos, using various strokes, find opponent's weakness.
 - How many points can be won by exploiting these weaknesses?
 - How many points do you lose when your weaknesses are exploited?

Remember

The weaknesses may not always be where you expect them. For example, if you decide that it is the backhand which is weak, it may not be the stroke itself but rather poor tactics or weakness caused by a certain style of play.

Example 2

- TACTIC** - Move opponent (wrong-foot opponent).
- WHAT?** - Where can the ball be placed to move opponent?
Change direction, for example, to forehand backhand or mid table. Length of shot, close to net or towards end line of table.
- HOW?** - By using a variety of ball placements around the table.
- TASK** - Working in twos, using push or topspin strokes, try a variety of footwork practices both regular or irregular. (See Figure 3.3.)

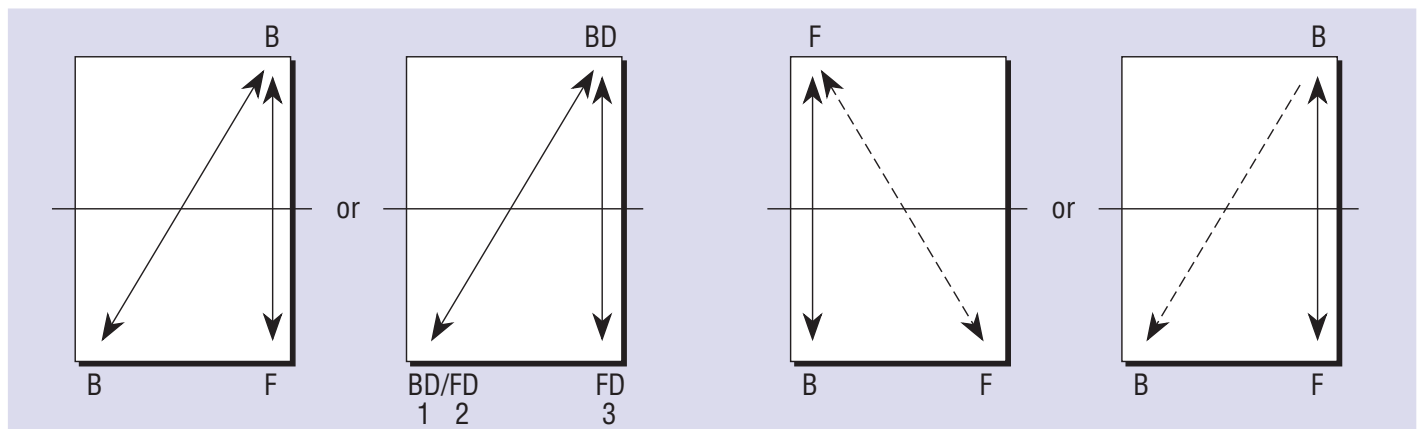

(See Figure 3.3.)

Example 3

- TACTIC** - Consistency of strokes.
- WHAT?** - Play ball one more time than opponent.
- HOW?** - By becoming consistent on all strokes.
- TASK** - In pairs, try to keep the ball going across the net to each corner. Aim for highest number of strokes in a rally. (See Figure 3.4.)

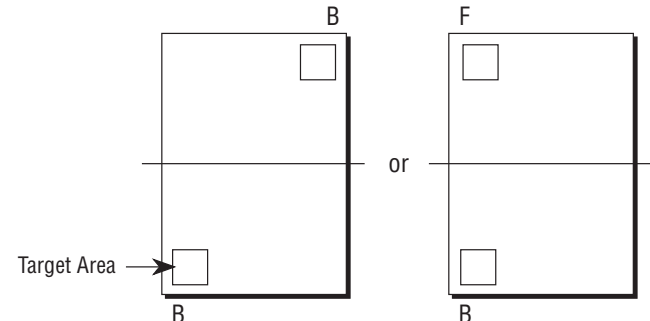

Figure 3.4

Example 4

- TACTIC** - Use of variety of strokes to beat opponent.
- WHAT?** - For example, attacking from a pushed ball.
- HOW?** - By combining strokes.
- TASK** - In pairs, one acts as feeder and one combines strokes. (See Figure 3.5.)

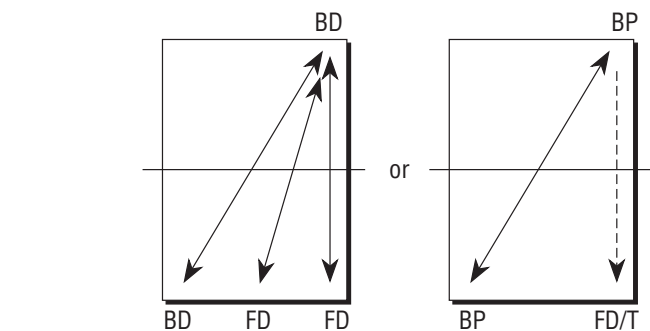

Figure 3.5



Example 5

- TACTIC** - Variation of spin.
- WHAT?** - By using various spin to make the receiver's task more difficult because it changes the flight path (trajectory) and alters the bounce.
- HOW?** - By imparting topspin, backspin or sidespin on ball.
- TASK** - Combine drive and topspin strokes or push and backspin (chop). (See Figure 3.6.)

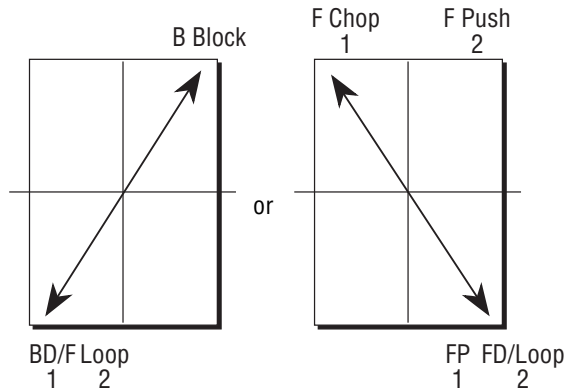

Figure 3.6

Example 6

- TACTICS** - Play on own strengths and specific style of play.
- WHAT?** - It is vital to play on own strengths whether defensive (away from the table), counter hitter/blocker or top spinner. Experiment to find the style which is most effective for you.
- HOW?** - Look at strengths and weaknesses of styles.
- TASK** - See Table 3.7

Style of play	Strengths	Weaknesses
Topspinner/Looper	<ol style="list-style-type: none"> 1. Gain maximum advantage from third ball attack. 2. Can vary spin and speed. 3. Continual use of spin makes it difficult for opponent to make opening. 	<ol style="list-style-type: none"> 1. Very physically demanding. 2. More time needed to recover, slightly longer strokes. 3. Vulnerable to changes in pace, to upset timing.
Counter Hitter/Blocker	<ol style="list-style-type: none"> 1. Speed of reaction and anticipation. 2. Taking ball early. 3. Uses opponent's speed and topspin. 	<ol style="list-style-type: none"> 1. Vulnerable to changes in pace and spin. 2. Often finds severe backspin difficult.
Chopper/Defender	<ol style="list-style-type: none"> 1. Patience and consistency. 2. Will vary the spin. 3. Most choppers use a combination bat of reversed rubber on one side and pimples on the other which produces different effects on the ball. 	<ol style="list-style-type: none"> 1. Can be moved about a great deal, in and out and from side to side. 2. May not be able to attack short balls.

Table 3.7





DOUBLES

Doubles in Table Tennis is different from every other racket sport because the rules state that the ball must be struck alternately and in a set order. (See Figure 3.8.)

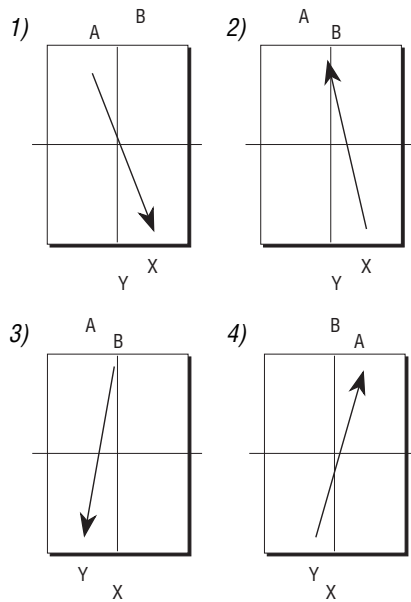

Figure 3.8

Service in Doubles

The ball must always be served diagonally from the right hand court. After service the ball may be returned anywhere.

In a match between players A and B against players X and Y, the service order is as follows:

A and B win the toss and select player A to serve.

X and Y then select player X to receive service.

First Game:

The first five points are served by A to X to B to Y and the sequence then repeats.

The second five points are served by X to B to Y to A.

The third five points are served by B to Y to A to X.

The fourth five points are served by Y to A to X to B.

This order repeats until the game is won. If the score is 20 all, the order remains but the players only have one service each.

Second Game: Either X or Y may serve first.

If X elects to serve first, the sequence is thus:

The first five points are served by X to A to Y to B.

The second five points are served by A to Y to B to X.

The third five points are served by Y to B to X to A.

The fourth five points are served by B to X to A to Y.

If Y elects to serve first, ask students to work out the correct sequence.

Third Game:

The order begins as per the first game until one pair wins 10 points. The players then change ends, and the order changes to that of the second game, until the game is won.

NOTE

At the change of ends the player who is serving continues to serve but the order of play changes.

Figure 3.9 illustrates the positioning for:

- a) Service - two right handers playing
 - one right and one left hander
- b) Return - two right handers playing
 - one right and one left hander

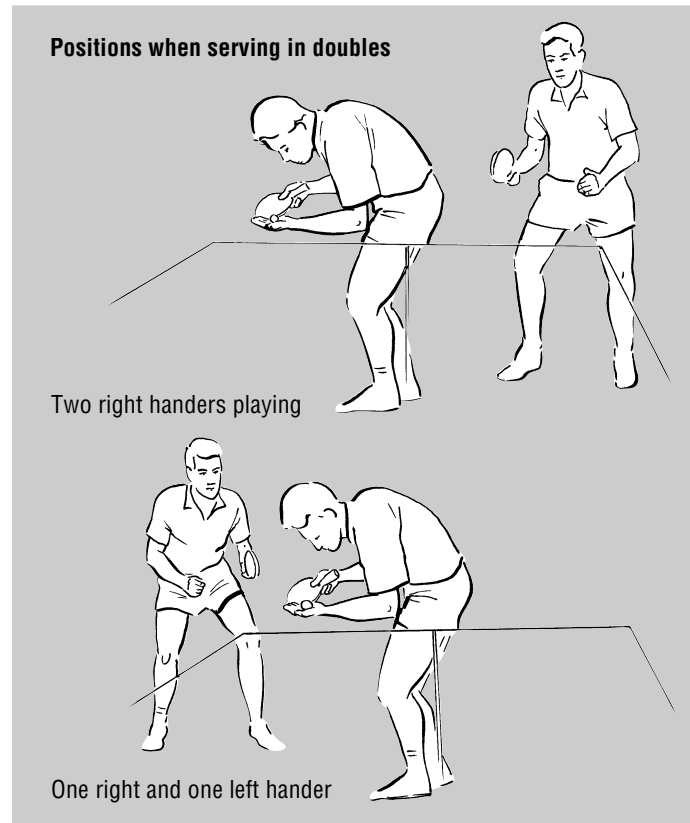

Figure 3.9a

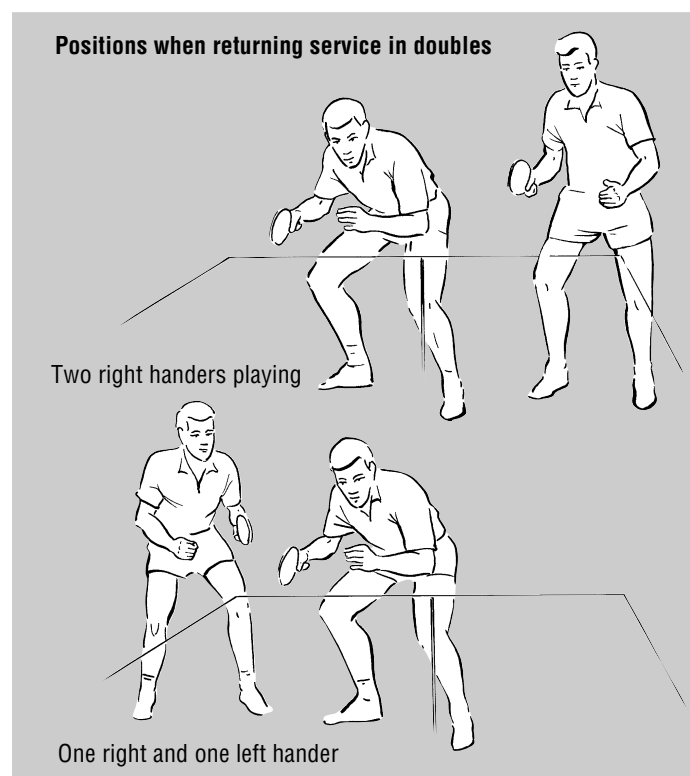

Figure 3.9b





UNIT 4 Assessment

The process by which assessment is undertaken is generally left to the individual teacher. Worksheet 1, as an example, demonstrates how assessment data may be recorded.

Assessment of students' work is an integral part of the National Curriculum. It is important that this is carried out as objectively and as unobtrusively as possible. The first point to be established in assessment are the criteria against which the students' work is to be measured.

Secondly, it is vital to know which are the important points to observe within a student's performance. It is therefore essential for staff to train themselves to select and observe the key points of any skill or tactic and not to be distracted and misled by extraneous information which may distort their judgement. The following are included as guidelines only and staff are advised that they should continuously attempt to improve their observation and assessment techniques.

Assessment is divided into two parts:

1. Ability to execute technique and skills.
2. Students' understanding of tactics, stroke variation and placement of the ball.

The following may be used to create situations within which assessment can take place.

- Task 1 Keep the rally going across the table e.g. BP to BP or F topspin to F topspin, repeat with each stroke (if not possible self feed, but do not rally).
- Task 2 Basic service and return. In pairs, five services each. Serve, return and end rally. To assess this, the teacher may select four different services.
- Task 3 Basic rally with element of movement. Examples of selected combinations might be:
- a) Combine push and drive
 - b) Combine topspins.

Points to check:

Technique, consistency, serving and adhering to laws.

- Task 4 Include service, and play out points in normal way, i.e. using the singles games.

Points to check:

Consistency, hitting ball away from opponent, in the right position at right time, scoring a game.





UNIT 5 Table Tennis, Laws, Equipment and Officials

Playing Conditions and Space Requirements

Where facilities are not ideal, it is simply recommended to make best possible use of what is available. Because space requirements in comparison with many other sports are small, Table Tennis can be easily played in a wide range of buildings and, indeed, is an ideal sport for many venues. It is normally played indoors by two or four players (singles or doubles) on a table of standardised size with a net across the centre. The balls are white, orange or yellow, and are made of celluloid or plastic.

Playing Conditions

Critical factors

- Overall playing area including specified clearances around, and clear height above, the table.
- Colour, reflection, friction and resilience characteristics of the floor.
- Floors and walls of dark (but not excessively so) non-reflective colour.
- Uniform light over playing area without any stroboscopic effect.
- Reduced lighting intensity over spectators outside the playing area (arena effect).
- Good ventilation but without air current.

Table Dimensions (See Figure 5.1)

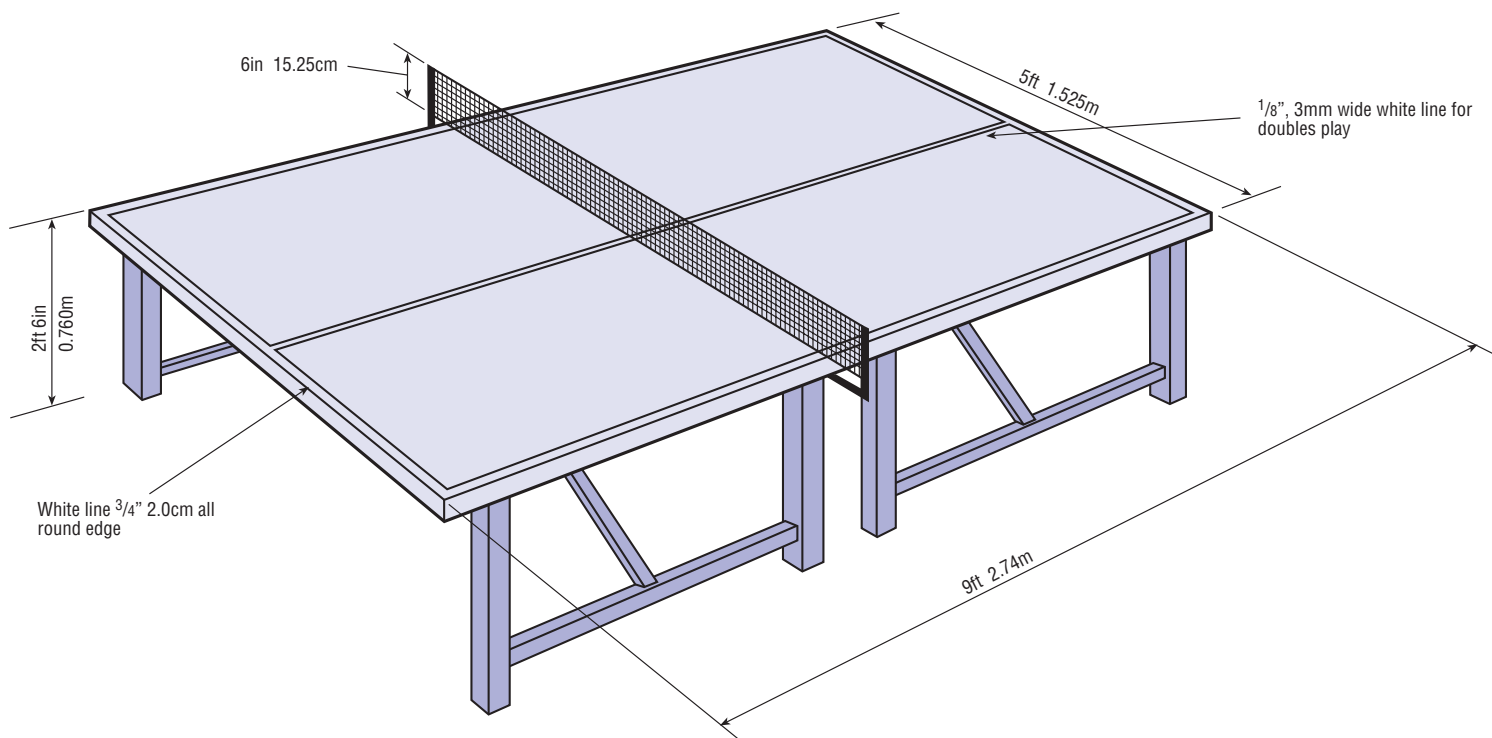

Figure 5.1





The level of play also dictates the dimensions of the playing area:

Standard of play	Grade 1 World Level	Grade 4 Local League	R (see note) Recreational/ Coaching Purposes
Length of playing area	14.0m	9.0m	9.0 - 8.5m
Width of playing area	7.0m	5.0m	4.57 - 4.12m
Clear height from floor to light fitting	4.0m	3.0m	3.0m
Clearance from end of table to barriers or other obstruction	5.65m	3.13m	3.13-2.88m
Clearance from side of table to barriers or other obstruction	2.74m	1.74m	1.53 - 1.3m

NOTE R

Increased dimensions are ranged from the ideal (maximum) to absolute minimum, taking into account the most economical use of small hall space and layout of tables.

Table 5.1

The Laws

The laws of Table Tennis are controlled and governed by the International Table Tennis Federation (ITTF). The following are extracts from the laws, a full copy can be obtained from the ETTA (see Recommended Reading).

The Racket (bat)

The racket may be of any size, shape or weight, but the blade shall be flat and rigid. At least 85% of the blade thickness shall be of natural wood. The surface of the covering material on a side of the blade or of a side of the blade, if it is left uncovered, shall be matt, bright red on one side and black on the other.

Definitions

1. A *rally* is the period during which the ball is in play.
2. A *let* is a rally of which the result is not scored.
3. A *point* is a rally of which the result is scored.
4. A *player obstructs the ball* if he/she, or anything he/she wears or carries, touches it in play when it has not passed over the playing surface or his/her court since last being struck by his/her opponent.

Service

1. At the start of service the ball shall be stationary, resting freely on the flat, open palm of the server's free hand, behind the end line and above the level of the playing surface.
2. The server shall then project the ball near vertically upwards, without imparting spin, so that it rises at least 16cm after leaving the palm of the free hand.
3. As the ball is falling from the highest point of its trajectory, the server shall strike it so that it touches first his/her court and then, after passing over or around the net assembly, the receiver's court.
4. The ball and the racket shall be above the level of the playing surface from the last moment at which the ball is stationary before being projected, until it is struck.

NOTE

Exceptionally, strict observance of any particular requirements for a good service may be waived where the umpire is notified, before play begins, that compliance with that requirement is prevented by physical disability.

A Let

A rally shall be a let if:

1. In service the ball, in passing over or around the net assembly, touches it provided the service is otherwise good or the ball is obstructed by the receiver or his/her partner.
2. The service is delivered when the receiving player or pair is not ready, provided that neither the receiver nor his/her partner attempts to strike the ball.
3. Failure to make a good service or a good return or otherwise to comply with the laws is due to a disturbance outside the control of the player.
4. Play is interrupted by the umpire or assistant umpire.

Play may be interrupted:

1. To correct an error in the order of serving, receiving or ends.
2. To introduce the expedite system.
3. To warn or penalise a player.
4. Because the conditions of play are disturbed in a way which could affect the outcome of the rally.

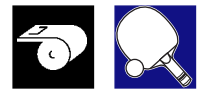

A Point

Unless the rally is a let, a player shall lose a point:

1. If he/she fails to make a good service.
2. If he/she fails to make a good return.
3. If he/she strikes the ball twice successively.
4. If he/she strikes the ball with a side of the racket blade which surface does not comply with the requirements.
5. If he/she, or anything he/she wears or carries, touches the net assembly.
6. If in doubles, except in serving or receiving, he/she strikes the ball out of proper sequence.
7. If, under the expedite system, he/she serves and the receiving player or pair makes 13 successive good returns.
8. If the umpire awards a penalty point against him/her.
9. If he/she, or anything he/she wears or carries, moves the playing surface.

A Game

A game shall be won by the player or pair first scoring 21 points unless both players or pair score 20 points, when the game shall be won by the player or pair first scoring subsequently 2 points more than the opposing player or pair. For example, 22-20, 25-23 and so on.

A Match

A match shall consist of the best of 3 or 5 games.

The Choice of Serving, Receiving and Ends

1. When one player or pair has chosen to serve or to receive first or to start at a particular end, the other player or pair shall have the other choice.
2. After 5 points have been scored the receiving player or pair shall become the serving player or pair and so on until the end of the game, unless both players or pairs have scored 20 points or expedite system is in operation, when the sequences of serving and receiving shall be the same but each player shall serve for only 1 point in turn.

The Expedite System

The expedite system shall come into operation if:

1. A game is unfinished after fifteen minutes' play, unless both players or pairs have scored at least 19 points, or at any earlier time at the request of both players or pairs.
2. The ball is in play when the time limit is reached, play shall be interrupted by the umpire and shall resume with service by the player who served in the rally that was interrupted.
3. The ball is not in play when the time limit is reached, play shall resume with service by the player who received in the immediately preceding rally of the game.
4. Thereafter, each player shall serve for 1 point in turn until the end of the game and if the receiving player or pair makes 13 good returns the server shall lose a point.
5. Once introduced, the expedite system shall remain in operation for the remainder of the match.

EQUIPMENT

Basic equipment requirements for Table Tennis are minimal (tables, nets, bats and balls) and relatively inexpensive. Naturally, as with the majority of other sports, there is a vast choice of different types of equipment and a whole range of playing accessories such as specialist shoes, clothing, bat rubbers, cleaner, thermo bat cases, a table tennis robot (ball feeding machines) and so on. Table Tennis should at all times be set out and played under appropriate conditions and with due consideration for the safety of participants and spectators. Equipment is easy to set out and, appropriately supervised, is very safe for young people.

Tables

Often, the quality of a table is determined by the table top thickness. Anything less than 18mm is not recommended. There are three main types of table (differentiated by the undercarriage) to suit storage and movement.

The **free-standing table** is the easiest for storage and takes up least space. Used for all levels of play, it has eight legs, with wheels built into the centre edge for easy movement to and from the storage area. Although most economical on storage space, it is more difficult to move and erect and should not be handled by young children unless under strict supervision. Free standing tables come as two separate halves and are the easiest and most suitable type of table for movement from one venue to another as they are easier for handling and moving in and out of vehicles.

The **rollaway table with playback facility** is easy to move and erect, although the way the table is mounted on the undercarriage makes it the most bulky to store. It also requires higher "headroom" (1.85m) for movement, as it is taller in its closed position than other tables. It has the advantage that it can be half closed, leaving one end of the table horizontal while the other end is vertical (playback facility) so a player can practise from the horizontal end against the vertical face of the table (like a tennis player practising against a wall).

The **fold and rollaway table** is easy to move and designed for economical storage. Two halves fold or wheel together almost flush, with the distance between the wheels being closer than the type above. Ideal for sports centres (no playback facility).

Nets and posts should be sturdy, simple to assemble and easy to attach to tables of any thickness. Removable nets and posts are recommended. Fixed nets can snap off and may protrude and hinder storage and safety.

Rackets (bats)

Most Table Tennis equipment has remained relatively unchanged since the introduction of the sport. The racket (or bat, as is the common term) is an exception with the changes mainly the result of the development of different playing techniques and technology. Basic bats can be purchased for under £5. However, bats for top class play can cost approximately £5 and in excess of £100.

The technical development of Table Tennis bats can be divided into three distinct eras, the 1880s – the early 1900s, the 1920s -1950s and the 1960s – 1990s. (See Figure 5.2.)





The Technical Development of Table Tennis Bats.

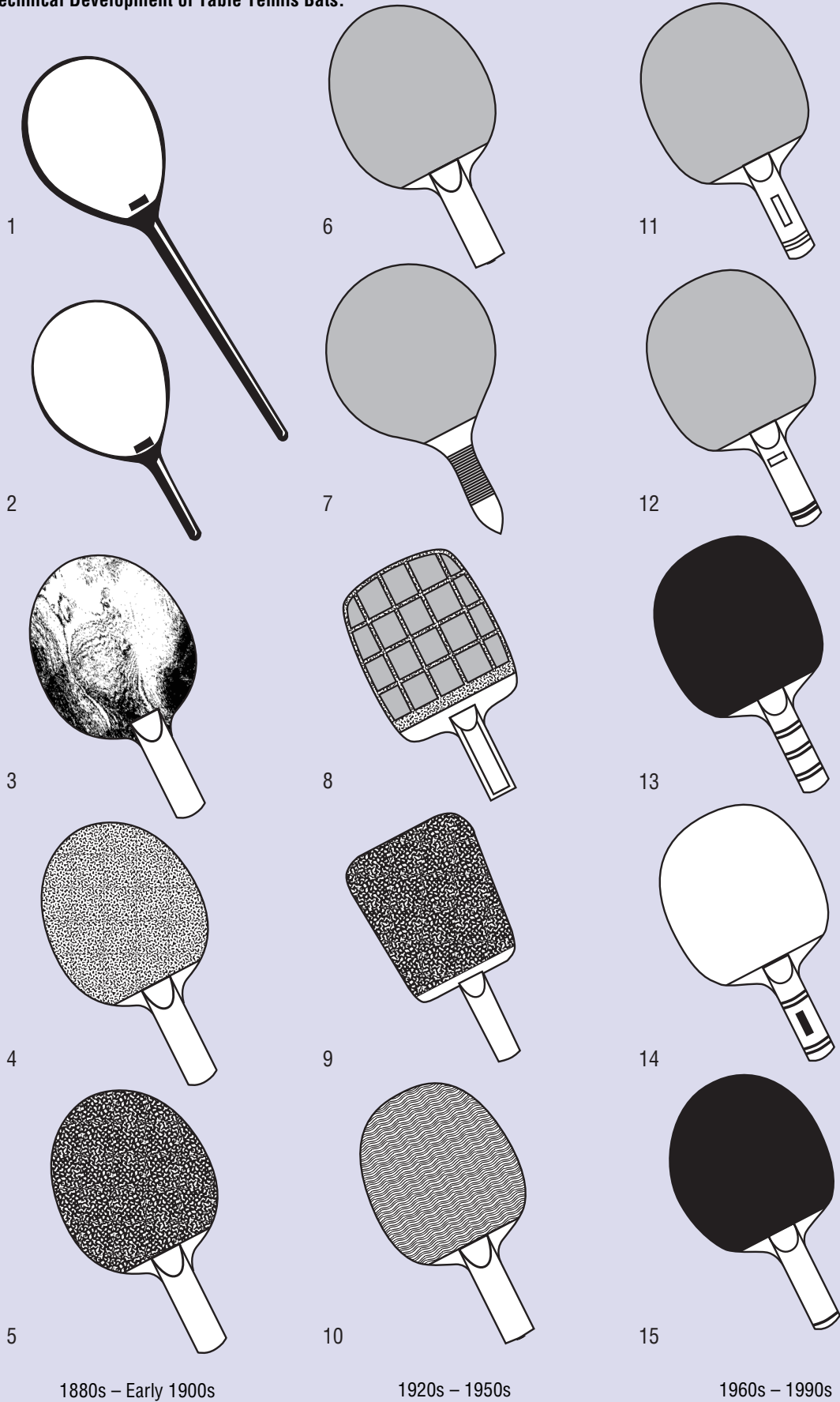

Figure 5.2

Reproduced from Table Tennis – the Early Years by kind permission of the I.T.T.F.





1880s – early 1990s

In rough chronological order, rackets developed as follows:

(See figure 5.2)

1. The long handled vellum battledore, frequently called the “banjo” racket and often as long as 48cm.
2. The short-handled hollow vellum battledore racket which superseded the long handled model.
3. The plain wooden bat which was made of different types of wood and in different thicknesses.
4. A bat faced in sandpaper was developed next in an attempt to help players impart spin on the ball.
5. The cord-faced racket replaced (4) above, and many players considered it gave improved performance.

1920s-1950s

This era saw many changes to the technical specifications of the racket, and for the first time the impact of Japanese technology was experienced by European players.

6. A pimped rubber bat which had a canvas backed rubber sheet, the surface of which was studded.
7. The next stage was the production of an extra wide bat which had a surface of pimped rubber. This bat was often preferred by defensive players.
8. In the early 1950s, a waffle sponge bat was introduced.
9. The 1950s saw the first Japanese bat on the European market. This was a 10mm soft sponge bat.
10. The introduction of the crêpe rubber bat was not successful owing to the fact that it gave the player little control over the ball.

1960s-1990s

This phase of development saw the bat evolve into the current hi-tech product it is today.

11. The first product in this phase was the 1mm pimped rubber sponge covered bat, but while this was suitable for all round play it did impose limitations on spin.
12. The above was superseded by the 2mm pimple rubber bat which proved ideal for attacking play, but again limited spin.
13. In terms of innovation, the next in line was a bat which was designed to counter topspin by providing a surface which would absorb heavy topspin.
14. The maximum degree of spin and speed was produced by a bat which had a 1mm reverse rubber sponge surface.
15. Finally, for greatest control, the 1mm reverse rubber sponge bat was produced.

Rubbers

These days, both sides of the blade are invariably covered with a layer of rubber and sponge. The nature of this combination influences the speed and spin which the user can impart onto the ball. Rubbers have various properties but are essentially of two types:

- a) Reversed (pimples in – smooth)
- b) Pimples out.

For greater speed and/or spin a greater thickness of sponge is used.

Balls

Originally thought to be made from cork progressing to India rubber, then Jaques' elastic and now celluloid or plastic.

THE ROLE OF AN UMPIRE

The umpire has the following basic responsibilities:

1. Checking table, net and playing area.
2. Timing and limiting warm-up to two minutes.
3. Tossing coin to see who chooses to serve or receive or chooses which end to play.
4. Checking bat is legal and has ITTF stamp.
5. Checking service technique is correct and to call a fault if not.
6. Calling out the score clearly, call server's score first and use “twiddler” score boards where provided.
7. Making sure service changes correctly.
8. Recording the score.
9. Calling lets, for example, if the ball hits the net and goes over in service, or if a ball comes across from another table and interferes with play.
10. Keeping the game and players under control.





UNIT 6 Physical Conditioning

PRINCIPLES OF TRAINING

When training physically for Table Tennis, it is helpful to be aware of the principles which underlie all training. This will provide the teacher/coach with a specific framework on which to base a training programme which will achieve the best possible results.

Conditioning is governed by three major principles:

Overload	A stress must be put on the different systems of the body for them to show improvement.
Progression	When the system is able to cope with the imposed stress then a progression in the training is necessary in the form of increased stress which will achieve further gains.
Regression	“If you don’t use it you lose it”, meaning that if exercise is stopped then the fitness level will decrease. The speed at which it decreases will differ depending upon the type of training and the initial level of fitness prior to the lay-off.

ELEMENTS OF TRAINING

While working within the underlying principles, there are a number of elements which are necessary to achieve the most appropriate level of fitness specific to Table Tennis.

Distance (Numbers)	The distance run or the number of exercises that are recommended. For example, a four mile run, 30 sit ups.
Intensity (Speed)	Speed at which work is carried out. A variation in intensity will not in itself increase effectiveness of any training programme but will avoid any training becoming mundane and repetitive.
Recovery (Active Rest)	The periods of rest between exercises. Variation in rest periods produces effects on different energy systems in the body.
Variety	Training should be designed to avoid the problem of boredom and of simply going out and running a certain distance every day. It is relatively easy to design alternatives which add variety and aid motivation.
Rest and Recovery	At least one rest day should be prescribed in any training schedule. It is important that performers rest on this day from any strenuous exercise, and that a sufficient amount of sleep is attained.
Safety	Within any training regime it is important that the player can distinguish between that which is safe and that which is painful but beneficial, and when pain is derived from an injury that needs resting or is produced from another health problem. Clearly, if the pain is related to injury then the exercise should be stopped immediately.

THE PHYSICAL DEMANDS OF TABLE TENNIS

Table Tennis is one of the few sports that can be categorised as a true fast-ball sport. The sport, at almost all levels of playing ability, requires the use of anticipation and extremely rapid actions on the part of all players. The physical demands of Table Tennis are, as with most sports, specific to that particular activity. As a result of this specificity, emphasis within training is placed on certain aspects of physical fitness.

In Table Tennis many different types of fitness play a role in the ideal fitness profile of a player. The following sections outline the different types of fitness, indicate their importance within the sport and give examples of how a particular aspect of fitness might be trained.

MUSCULAR ENDURANCE The ability to maintain specific muscular activity over a prolonged period of time.

Table Tennis requirements Specific muscles are involved in repeated action during stroke play.

Examples of Training Muscular Endurance for Table Tennis

Circuit Training Working against body weight, the following example details a sport specific circuit of 10 exercises repeated 10 times:

- Star jumps
- Elbow to knee sit ups
- Side steps
- Burpees
- Press ups
- Step ups
- Dorsal raises
- Squat thrusts
- Lunges – forward and backward
- Continual twisting sit ups

Target Circuit Where specific exercises are chosen and a maximum number completed in a minute is recorded. A percentage of this maximum (usually between 50% and 75%) is set as the target. For example:

- Tuck jumps – knees to chest.
- Press ups – one of four versions, from knees, normal, hands close together, or hands wide.
- Star jumps.
- Squat thrusts – both “normal” and split.
- Burpees.
- Sit-ups of different types, for example, “normal”, knee to chin, twisting, continual twisting.
- Dorsal raises – lying on floor raise head and chest up with feet on floor.
- Lunges – one minute side lunges pushing off as hard and fast as possible. Repeat front and back.
- Skipping.
- Snake press ups – the body undulates rather than being kept straight.
- Dips.
- Leg lifts – one leg at a time.
- Step ups onto a bench.
- Chins – with either inward or outward facing hand grips.

Interval Training Training which comprises flat-out running with a recovery between bouts of exercise. The main way of manipulating this form of training is to vary the ratio of running to recovery. Interval training has possible benefits for the cardiovascular system, but the principle training benefits are to be found in muscular endurance adaptations. One example of using time periods which relate to the demands of Table Tennis is a 15-15 run. This is simply the amount of time for which the player jogs and sprints, i.e. jog 15 seconds, sprint 15 seconds and so on for a maximum of 10 minutes. If possible use a





watch that will give a signal every 15 seconds, or estimate the relevant time span.

CARDIOVASCULAR ENDURANCE The ability to maintain an effective supply of oxygen, transported by the blood to the working muscles.

Table Tennis requirements Table Tennis requires a high level of cardiovascular endurance in order to aid recovery after the bursts of short sharp activity and also to enable players to continue to play over the course of a tournament day, or simply to be effective throughout one match that could last for up to one hour in length.

Examples of Training Cardiovascular Endurance for Table Tennis

Steady State Running Running at a pace at which the player is just able to hold a continuous conversation.

Fartlek Running with a change of speed for a specific period of time. For example, running approximately 80 metres at each pace using a “sprint, jog, walk” cycle. Additionally, the player may do “strides” i.e. running, concentrating on extending stride length and high knee lift. Many people train with fartlek distances based on the distances between lamp posts.

Maximum Steady State Running Running for approximately 25 minutes, where the player maintains a pace sufficient not to be able to maintain a continuous conversation. This type of pace should be reached in about the first four minutes of the run and then maintained for the rest of the time.

STRENGTH TRAINING

In many sports the use of strength training is widespread amongst performers. In Table Tennis, however, the demands of the sport do not need a level of strength requiring regular weight training. In fact, the use of weight training has often been attributed by professional players to a shortening of their careers due to resultant back problems.

Although if carried out under professional assistance, weight training could be advantageous, the possible benefits to Table Tennis would be seen as negligible. This, combined with the possibility of chronic or long term injury, make this aspect of training the least important for the Table Tennis player.

DYNAMIC STRENGTH (Speed) The ability to produce maximum force from the appropriate working muscles.

Table Tennis requirements Movements within Table Tennis are of a very short length and demand great speed.

Examples of Training Dynamic Strength for Table Tennis (Speed)

Plyometrics A type of exercise used to develop elastic strength of muscles. There are many ways in which this can be trained such as the use of jumping, bounding, bouncing and hopping.

NOTE

It is important that before beginning any plyometric training the appropriate leg conditioning work has been carried out in order to cope with the rather strenuous nature of the activity. If this level of conditioning is not in place then damage to joints and muscles may result. It is advised that no plyometric training should be carried out with individuals under the age of 14.

Examples of plyometric training:

Hopping on grass or other soft surface, player always faces in the same direction and hops continuously backwards, forwards and sideways following the outline of an imaginary Union Jack.

Skipping as fast as possible for one minute.

Line jumping, side to side, over a line as fast as possible for one minute.

Shuttle Running Based on sprints carried out at full pace over short distances (60, 40 or 20 metres) with intervals of recovery in between.

FLEXIBILITY The ability to move a joint through a maximal range of motion.

Table Tennis Requirements Without mobility in the joints, many of the movements necessary to achieve maximum performance will not be achievable.

Examples of Increasing Flexibility for Table Tennis

Within any training programme, flexibility should play an important part. It is important that the difference between flexibility and stretching is clear and that flexibility exercises are completed and not simply stretching.

Stretching A movement that will lengthen a muscle to the point at which the stretch is felt.

Flexibility Stretching slightly further than above and maintaining this position for a short period of time. By doing this type of work the player should increase the range of movement.

Increased flexibility is not only important for increasing range of movement, but also in injury prevention. Flexibility sessions are crucial to the success of any training programme, as without this type of work the player is in danger of losing a certain amount of range of movement as muscle size increases.

When performing a flexibility session the following should serve as guidelines. The player should:

1. Always warm up by jogging slowly for approximately five minutes followed by stretching. This serves to warm the muscles and minimise the risk of injury.
2. Hold the stretched position for approximately seven seconds (in order to become aware of the point of maximum comfortable stretch) then release.
3. Return to the stretched position and push a little, hold for a further seven seconds and release.
4. Repeat three times.
5. Move onto next muscle group.





Flexibility Exercises for Table Tennis

For Table Tennis the player should concentrate on the following areas of the body:

- 1) Inner thigh.
- 2) Ankle extension and flexion.
- 3) Hips and groin – soles of feet touching and gently pushing down the knees.
- 4) Hamstring – keeping the back straight, pull the leg towards the body keeping the leg straight.
- 5) Trunk – bend to either side keeping hips stationary.

(Following are not illustrated).

- Trunk – right foot crossed over left knee, left elbow on right knee, right palm on floor, twist trunk and head from left to right.
- Trunk – back to a wall, reach round and put the palms of hands on wall.
- Dorsal – lie face down on floor, hands forward, lift the head and legs approximately 10cm.
- 6) Lower back – kneel with hands flat on floor. Lift right arm and left leg and extend horizontally (repeat with left arm and right leg).
- 7) Arms and shoulders –
 - (a) Hands together above the head, push the head forwards and the hands back with the arms straight.
 - (b) Hands on wall, push the shoulders downwards.
 - (c) Join the hands over one shoulder and pull.
 - (d) As before but using a towel.
 - (e) Hand on the opposite elbow and push backwards.

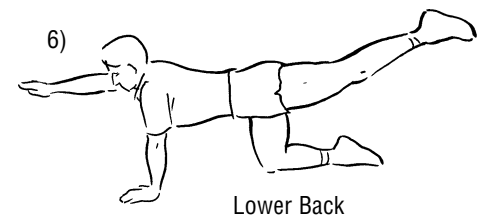
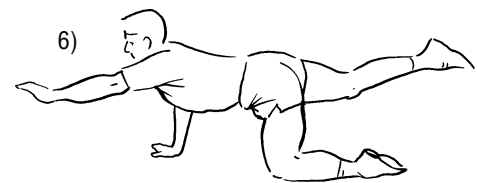
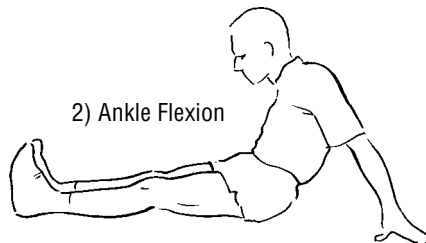
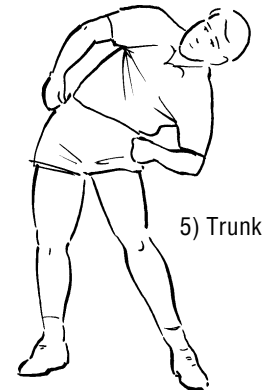
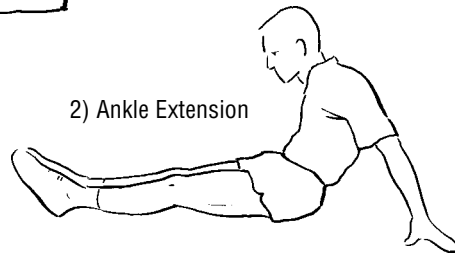
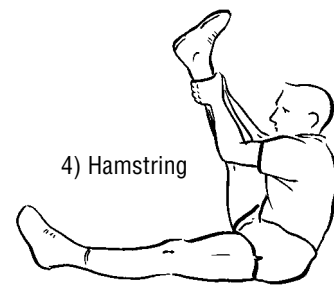
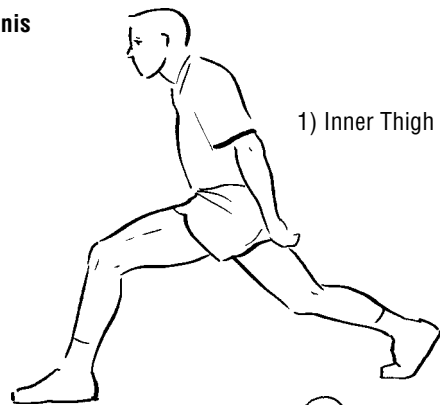

Arms and
Shoulders

7a)



7b)

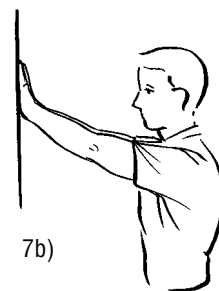

7c)



7d)



7e)

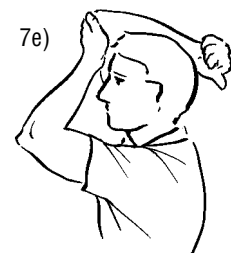

NOTE

To perform the above exercises, players should already have a reasonable level of fitness to avoid undue stress on joints. Adaptations can be made for less fit players.





11. Time keeping.

“ON TABLE” FITNESS TRAINING

Time spent on the table is often seen as being solely for the purpose of developing good technique, or for practising particular match plays. However, there are a number of ways in which table time can be used for sports specific fitness. Examples of “On Table” physical training for Table Tennis:

Ball Firer (Robot)

Using a ball firing system (e.g. a robot), a large number of strokes can be played in a short period of time demanding varied levels of physical exertion.

Differential demands can be placed on the player by adjusting the number of balls fired per minute and the areas of the table to which the balls are propelled. Firing into one particular spot is used primarily as an aid to technical development of stroke patterns, whereas random placement provides excellent cardiovascular and local (specific) muscular demands on the player.

Shadow play

Shadowing strokes in particular sequences can be a very effective way of simulating Table Tennis rallies. This can extend the player’s stroke and movement sequence beyond the length normally found during a game where the length of rally is dependent on the opponent returning the ball. This can be helpful especially in the development of muscular endurance.

Multi-ball

This technique is very similar to the ball firer technique but, in this instance, the coach or another player feeds balls continuously to the player. The use of different feeding sequences and rates of feeding can determine the types of fitness which can be improved.

“On table” physical training is an essential component of a Table Tennis player’s fitness work, and the versatile nature of the techniques described indicate the multiple benefits which can be gained by incorporating such methods into any fitness programme.

INJURY PREVENTION AND MAINTAINING QUALITY TRAINING

Warming Up and Cooling Down These are crucial to the success or failure of any training schedule. Warming up properly helps to avoid injury and cooling down clears the system of the chemicals in the body produced by the exercise that can result in muscle stiffness. To warm up and cool down correctly enables the player to train more freely, more often and, as a result of this, more effectively. A warm up and cool down refers to a period of light exercise and stretching that would last for approximately ten minutes, i.e. five minutes of stretching and flexibility and five minutes of very light jogging slowing to a walk. This should be completed immediately before and after each session.

Equipment and Clothing With any physical training it is important to use the correct equipment. This will not only prevent the possibility of injury but increase the effectiveness of the training as a whole. Important points to remember are to always:

1. Run on grass or soft surfaces rather than on the roads.
2. Run in a pair of shoes that will support your ankles sufficiently and not in flimsy Table Tennis shoes. Joggers are ideal for longer distances whereas for sprints and shuttle runs (which should always be done on grass when possible) tennis type shoes (cross training shoes) are possibly the best.
3. Warm up in an extra layer of clothing to that in which you actually carry out the session and put this back on before you cool down or do the flexibility work. This outer layer should be something like a track suit or waterproof suit that will help you to keep warm but does not restrict movement.





UNIT 7 Mental Preparation

The mental aspects of Table Tennis play an important role in the overall profile of a performer so it is important to develop the whole player. This psychological element is possibly the single most difficult factor for coaches, teachers and performers to control and improve.

Most players and teacher/coaches do regard the psychological side of playing Table Tennis as important, (hence such statements as “It’s all in the head” or “You’ve got to get psyched up for this one”) and there are a wide range of psychological techniques that can be employed to boost performance both in training and within the competition cycle in the pre, during and post phases. Table 7.1 provides a list of some specific psychological skills related to the areas of performance to which they are most applicable:

PSYCHOLOGICAL SKILL TRAINING FOR TABLE TENNIS

In Practice	Pre-Match	Matchplay	Post-Match
Motivation profiles	Relaxation	Concentration	Performance evaluation
Goal setting	Positive thinking	Control over thoughts	Goal assessment
Coaching style	Focused	Emotional control	
Desensitisation/ Simulation training	Imagery	Positive thinking	
Enhancing self confidence			

Table 7.1

In order to get the best out of every player, it is important that teachers have an awareness of individual levels of motivation. A flexible teaching style is required as each individual teacher’s usual style (e.g. autocratic, democratic) may not be conducive to getting the best out of each individual player. The style used will depend on the situation and people involved. The achieving of mutually agreed goals set by the student and teacher together can act not only as a very effective motivator but also as a boost to self-confidence.

Pre-competition/Training

The practice/training environment is the ideal place to help performers gain experience of competitive situations and the different environmental and external factors (e.g. umpires, crowds, etc.) encountered there. Simulation training where such factors are brought in to the practice environment can help players to cope with the distractions present in competitive situations. An example of this would be to have the class or team mates creating a noisy training environment. A player who can sustain concentration in this type of environment is more likely to be able to do so under the increased pressure of competition.





Matchplay

Pre-match preparation

Many Table Tennis players have a well practised physical warm up and certain technical aspects which they will try to practise (e.g. service and return) along with “grooving in” basic strokes before a match. But, as indicated, the often forgotten but vital psychological element needs addressing, too, and the general aims of a psychological aspect of a warm up would be to help the player to be:

- RELAXED - The use of brief relaxation exercises prior to a game often used with imagery.
- POSITIVE - The player should develop positive phrases to use prior to performance and imagery based on best performances from the past.
- FOCUSED - It is important to establish realistically achievable and measurable goals related to each game. These should be measured post-match.

Such skills are a crucial element in any preparation for competition, and for many practice sessions. A correct and consistent psychological focus achieved before, and maintained during a game is often given as the reason behind resulting success or failure on the table.

In game

The skill of a performer in controlling how and what they are thinking, their level of physical tension and their emotions can often play a major role in the result of the match itself. Thinking about the right thing at the right time, or the ability to concentrate, is an essential component of thought control which can be developed by any player, along with maintaining a positive approach to the game through the use of positive thoughts to lift themselves or to counter the effects of a previous negative thought.

Between Rallies

To aid positive thoughts and good concentration in competition performers follow a process or sequence as follows:

- To forget the result of recent actions and results. This is designed to clear the mind of anything over which there is no control.
- Take two or three deep breaths. This is to rest the concentration for a few moments by diverting the attention to the breathing.
- Decide on the tactic to be played.
- The performer then visualises himself/herself playing the rally with the selected tactic successfully.
- Play the rally.

Post match

An important principle to instil in performers is to learn from every situation regardless of the result. This can function through the use of a performance evaluation sheet where positive and negative aspects of the performance can be written down. This form can then act as a basis of an evaluation of previously set goals for the performance, and guide the goal setting process for the next performance.

With any psychological skills, their development should follow a similar approach to training technical skills, i.e. with practice they can be improved. The importance of players practising the psychological skills both away from the table and during practice before taking them into the match play scenario increases the chances of success when used under pressure situations.

It is important for the teacher/coach working with Table Tennis players at all levels of ability to be aware of the individual needs of players. Specific psychological skills that are likely to work best will depend on the characteristics of the individual player.





UNIT 8 History of Table Tennis

In the development of Table Tennis the following are significant milestones:

- | | |
|--|--|
| <p>1880s Adaptation of lawn tennis to the dining table with improvised equipment.</p> <p>1890s Several patents registered in England, for example, Ping Pong and Whiff-Waff were sold with simple rules.</p> <p>1900 Development of celluloid balls to replace rubber and cork ones.</p> <p>1901 Table Tennis Association and rival Ping-Pong Associations formed in England, and the first books on the game were published.</p> <p>1926 International Table Tennis Federation (ITTF) initiated in Berlin. First World Championships held in London. The Constitution and Laws of the game adopted at the First ITTF Congress, also held in London. The English Table Tennis Association inaugurated and constituted.</p> <p>1929 Fred Perry (England) became World Champion.</p> <p>1935 The 9th Congress agreed to delete from the ITTF Constitution all references to the words "amateur" and "professional" and to substitute "player".</p> <p>1937 To encourage attacking play:</p> <p style="margin-left: 20px;">i) the net was lowered from 6.75in to 6in (17.2cm to 15.24cm)</p> <p style="margin-left: 20px;">ii) a time limit of twenty minutes for each game was imposed</p> <p style="margin-left: 20px;">iii) finger spin was prohibited</p> <p>1949/51 Johnny Leach (England) became World Champion and was later awarded an MBE.</p> <p>1950s The emergence of sponge sandwich bats.</p> <p>1953 England won the Swaythling Cup (World Men's Team Championship).</p> <p>1957 European Table Tennis Union inaugurated in Stockholm, Sweden.</p> <p>1958 The first European Championships held in Budapest, Hungary.</p> <p>1961 Expedite system adopted by ITTF.</p> <p>1967 The European League competition inaugurated.</p> <p>1970s The emergence of the combination bat, i.e. anti-loop, and long pimples.</p> <p>1971 Western teams invited to tour China for the first time, and the concept of "Ping Pong" diplomacy came into being.</p> <p>1972 Period of experimentation with yellow balls.</p> <p>1976 Permanent secretariat of the International Table Tennis Federation (ITTF) set up in St Leonards-on-Sea, England.</p> <p style="margin-left: 20px;">Jill Hammersley (England) became European Champion.</p> <p>1977 The 34th World Championships held in Birmingham. The ITTF received formal declaration of its recognition by the International Olympic Committee (IOC).</p> <p>1978 Jill Hammersley awarded an MBE.</p> | <p>1979 First European Championships for paraplegics (wheelchair players) held in Stoke Mandeville, England.</p> <p>1980 John Hilton (England) became European Champion.</p> <p>1981 Table Tennis admitted into the Olympic Programme (84th session IOC).</p> <p>1982 The first World Veterans' Championships held in Gothenburg, Sweden.</p> <p style="margin-left: 20px;">First World Championships for the Disabled held in Stoke Mandeville, England.</p> <p>1985 Racket coverings restricted to black and bright red, and prize money limit removed (38th Congress).</p> <p>1987 Desmond Douglas (England) European Top twelve champion and awarded an MBE.</p> <p>1988 Table Tennis featured in the Olympic Games (Seoul, South Korea).</p> <p>1990 The Chinese player, Chen Xinhua, former World No.4 selected to represent England.</p> <p>1992 Jan-Ove Waldner, reputed to be the first Table Tennis millionaire, became Olympic Champion.</p> <p>1994 The 19th European Championships held in Birmingham at the National Indoor Arena.</p> <p>1995 Record number of countries represented at World Championships in China.</p> <p>1996 Jan-Ove Waldner of Sweden secured the European Men's Singles title making him the only player to have won singles titles at Olympics, World and European Championships.</p> <p>1997 South Africa back into Commonwealth and World Table Tennis Championships.</p> <p>1998 Lisa Lomas, England's leading female player of the decade, retired from competitive play.</p> <p>1999 World Championships to be hosted in Belgrade postponed because of war in the former Yugoslavia.</p> |
|--|--|





UNIT 9 The Structure of Table Tennis

Like all sports, Table Tennis is governed by both national and international bodies. For example, there is both a World and a European organisation in addition to the National body, the ETTA. As with many sports within the UK there are bodies set up to deal with Olympic competition, i.e. when a team is required to represent Great Britain.

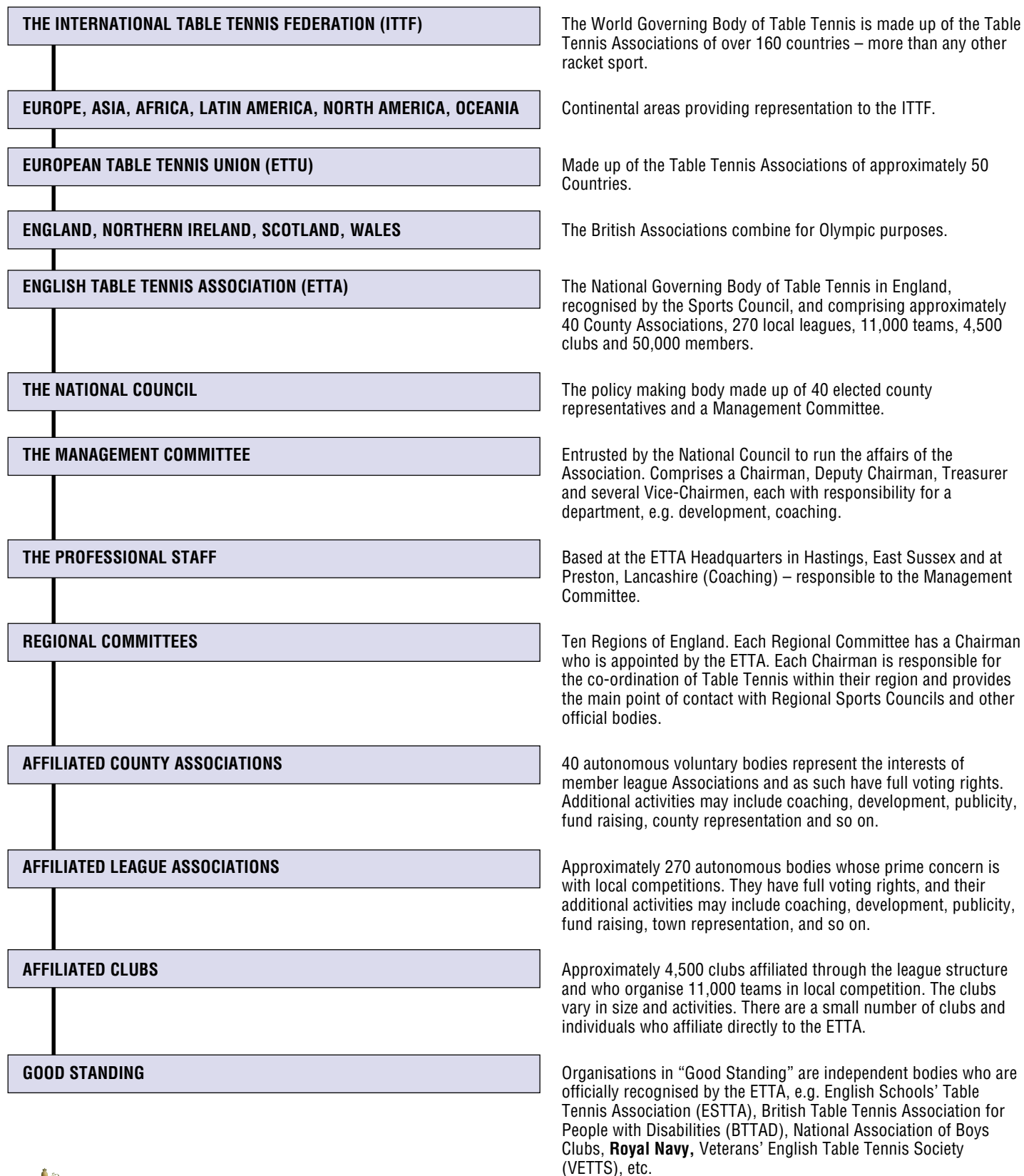



UNIT 10

Current Issues in Table Tennis

SPECIALIST TABLE TENNIS FACILITIES

Being a very versatile sport enables Table Tennis to be set up literally wherever there is space. Traditionally, therefore, Table Tennis has been played in a variety of locations such as church halls, youth clubs, sports clubs, pavilions as well as schools and leisure centres. The downside of this versatility has resulted in the sport “making do” with facilities and conditions not totally right for the sport, e.g. poor lighting, light coloured walls, limited table availability.

To improve the quality and quantity of Table Tennis facilities which are appropriate for the sport and available for play on a regular basis, Table Tennis now has an ambitious facilities programme. Resource material such as technical specifications, feasibility, business planning, grant aid advice, etc., is being made available to assist clubs and other interested parties in developing first class Table Tennis facilities.

EQUAL OPPORTUNITIES AND PARTICIPATION BY UNDER-REPRESENTED GROUPS

Barriers sometimes presented by sports can discourage participation by some sections of the community, e.g. people with disabilities, women, veterans, ethnic minorities, low waged, and so on. In Table Tennis, all sections of the community are encouraged to participate, and the English Table Tennis Association has produced an equity policy.

Women in Table Tennis

Clearly in Table Tennis, like many other sports, there is under-representation by some groups. To counter this, positive action has been taken. An example of this is the “Women and Girls in Table Tennis” campaign which includes regional coaching rallies and leagues, the formation of a national women’s committee, the formation of the Women’s British League, increased opportunities for international training/competition for elite players and the development of promotional leaflets and posters.

Players with a disability

A development plan “Enhanced provision for players with disabilities” has been produced. In addition the British Table Tennis Association for People with Disabilities (inaugurated in 1993 by Sports Council Chairman Sir Peter Yarranton) has been formed. The BTTAD has established a close working relationship with the senior governing body, the English Table Tennis Association, resulting in:

- Mutual representation on national, regional and sub committees.
- Work concerned with disabled facility and equipment provision, coach education, disability awareness.
- Production of colour contact leaflet.

IMAGE/MEDIA/PUBLIC RELATIONS

Table Tennis is working towards a higher image and awareness both within the sport and with the public at large. The aim is to dispel commonly held myths which detract from the highly athletic, skilful and attractive modern sport that Table Tennis is today. A full time Information Officer has been recruited to work on increased coverage and editorial throughout the range of media outlets in a bid to portray the sport as it is: exciting and accessible.

Communication and public relations are deemed vital if the sport is to make a significant impact and work towards the increased exposure currently enjoyed by the so called “major sports”.





LIQUID ADHESIVES (Fast Glues)

The practice of regularly regluing rubber onto rackets is proven to increase the spin and speed of a ball by approximately 4% and 12%, respectively. However, scientists have exposed dangers associated with harmful vapours from “speed glues”, and in England such use has been banned.

The English Table Tennis Association is concerned with promoting a safe sport and has taken a leading role and a very strong line at European and International meetings in a bid to outlaw this practice. This “moral high ground” has been applauded by the Sports Council, however, it does leave “non glue users” at a disadvantage when competing against “fast glue users” from foreign countries.

Many countries are strongly resisting a move by the world governing body (ITTF) to ban liquid adhesives in preference to safe pressure sensitive adhesives. Already, lobbying by top players and the trade (suppliers of glue) has persuaded the ITTF to defer a world ban, firstly from September 1993 to June 1994, and then to August 1995.

NOTE

An increase of both spin and speed has generally resulted in shorter rallies, which some say is less exciting and less televisual.

EQUIPMENT DEVELOPMENT

Equipment development has been most prominent with the racket (bat) and rubbers. It has been primarily related to spin, speed and power. However, fashion has influenced other items, e.g. colour of tables and particularly clothing, which has moved away from staid one colour designs to bright and attractive items, including numerous accessories such as bags, bat cases, t-shirts, towels, and so on.

FUNDING/SPONSORSHIP

Nationally, funding for Table Tennis is channelled through the English Table Tennis Association. Some core funding to maintain activities is received annually from the Sports Council. (The Sports Council is charged by the government’s Department of National Heritage to distribute treasury monies for sport). The ETTA (like all sports applying for funds) writes and presents a four year forward development plan outlining the current situation, the way forward and how plans will be implemented. This is discussed and evaluated by members of the Sports Council and funds are apportioned as appropriate, with sports receiving different amounts according to the merits of such items as membership size, past records and future objectives, etc.

In addition to Sports Council funding, the ETTA’s income also includes membership subscriptions and its own income-generating activities which can include staging events, and sponsorship. The Association has a number of sponsors (time limited contracts) for a variety of activities ranging from trade (equipment suppliers) to commercial (e.g. Friendly Hotels plc and Woolwich Building Society) and other statutory and non-statutory bodies such as local authorities and Foundations.

On a local basis, clubs, individuals and other Table Tennis organisations often have local sponsorship which ranges from direct financial help to “in kind” assistance such as printing, free or reduced rent, grants for courses, etc, for example the McCain Scarborough and District Table Tennis Association, Woolwich Junior British League, Pfizer School-Club Link programme.

NOTE

Sponsorship for sport in the late 1980s and early 1990s has predominantly been monopolised by the few big media sports such as rugby, tennis, golf, football, cricket, etc. This leaves the so called minority sports battling for severely limited sponsorship opportunities. Inevitably many companies face economic difficulties which results in a streamlining of marketing plans and sponsorship deals. To combat this, the ETTA has a very strong marketing department including a full time Marketing and Promotions Director whose prime role is to maximise income to the sport.

NATIONAL VOCATIONAL QUALIFICATIONS (NVQs) in Table Tennis Coaching

Possession of a National Vocational Qualification (NVQ) reflects what a person is able to do and not just what they know. It is a measure of competence which is judged against industry and led nationally to agreed standards. Vocation Qualifications (VQs) are not only being applied in sport, but also in commerce and industry which should mean that coaches and others working in sport are acknowledged as holding qualifications which have the equivalence of other areas of work. Along with many other governing bodies of sport, Table Tennis are refining existing coaching qualifications to meet NVQ requirements, and are working closely with the National Coaching Foundation on implementing VQs within the field of coaching.

WORLD CLASS PERFORMANCE PROGRAMME

Sport England through Lottery funding has allowed the opening of the National Centre for Table Tennis based at the national sport centre at Holme Pierre Pont, Nottingham.





UNIT 11

Award Schemes

ETTA NATIONAL COACHING SCHEME COACHING AWARDS

The ETTA Coaching Award is open to anyone over 16 years of age interested in coaching Table Tennis. It involves a six hour course which aims to give a basic introduction to coaching Table Tennis. A certificate of attendance is issued on completion of the course.

ETTA Sport Leader Award The requirements for this are:

1. The candidate must be employed in a local authority or commercially operated leisure or sports centre.
2. Register as a Student Coach.
3. Attend 12 hour ETTA Coaching Course.
4. Satisfy assessment criteria.

ETTA Teacher Award The requirements for this are:

1. The candidate should be a qualified teacher, be undergoing teacher training or be working within community or youth services.
2. Register as a Student Coach (level 1 or level 2).
3. Attend 12 hour ETTA Coaching Course.
4. Satisfy assessment criteria.

The ETTA Coach Level 2 The requirements for this are:

1. Experience as a player.
2. Register as a Student Coach (level 2).
3. Attend 12 hour ETTA Coaching Course.
4. Attend practical sessions at designated centres (12 hours).
5. Satisfy assessment criteria.

The ETTA Coach Level 3 The requirements for this are:

1. One year's experience as an ETTA Coach Level 2, working regularly within the National Coaching Scheme.
2. Attend 12 hour Advanced Coaching Course.
3. Attend three, four hour, NCF Level 2 Courses – "Mental Preparation for Performance", "Motivating your Athlete", "Understanding and Improving Skill".
4. Purchase NCF Coaching Handbook No. 3 – "Psychology and Performance".
5. Attend four open tournaments, including at least one 3/5 star and one junior select.
6. Obtain pass on County Umpire Test Paper.
7. Submit written paper covering personal plans, over the next two years, within the National Coaching Scheme.
8. Satisfy assessment criteria.

The ETTA Coach Level 4 (Senior) The requirements for this are:

1. Two years' experience as an ETTA Coach Level 3, working regularly within the National Coaching Scheme.
2. Application accepted by the National Assessment Panel.
3. Attend two, 12 hour, NCF Level 3 Courses, "Mental Training" and "Training for Peak Performance".
4. Satisfy assessment criteria.

THE DUNLOP SKILLS AWARD SCHEME

This is an incentive scheme which provides badges and certificates for young people. There are Five Awards:

The Dunlop Skills Awards are open to every one (able bodied and the disabled). Awards have been devised for people who have never picked up a Table Tennis bat before, right through to an award for aspiring champions:

- (a) **The Dunlop Rookie** – Teaches the basic skills such as stance, position, simple movement, consistent ball control, and the service.
- (b) **The Dunlop Improver** – Develops control and introduces the four basic strokes, teaching candidates how to play a steady rally.
- (c) **The Dunlop Player** – Introduces spin, stroke combinations and tests the candidate's knowledge of the laws of the game.
- (d) **The Dunlop Matchplayer** – Tests candidate's ability to combine strokes incorporating movements, including winning rallies. Candidates are required to demonstrate the ability to score a match correctly.
- (e) **The Dunlop Masters** – Successful candidates will have acquired excellent ball control and will have developed a range of advanced level stroke techniques.

Award assessments

The opportunities for assessment are many and varied. The Rookie, Improver and Player awards can be assessed by ETTA Student Coaches, ETTA or ESTTA County/League Officials, Teachers/Student Teachers, Community/Youth Workers, Sports/Leisure Centre Staff. For Matchplayer and Masters' Awards, Assessors should, as a minimum, be an ETTA qualified Level 2 Coach.

How to Apply

The Awards can be taken at schools, sports/leisure centres, Table Tennis clubs and Youth clubs all over the British Isles. For further information, contact The Awards Administrator at the English Table Tennis Association (for address see Useful Addresses) who will send you a Dunlop Skills Awards package.





RECOMMENDED READING

ETTA Basic Coaching Manual (English Table Tennis Association)
ETTA Advanced Coaching Manual (English Table Tennis Association)
Know the Game Table Tennis (A & C Publishers Ltd)
How to coach Table Tennis – David Hewitt (William Collins and Son)
The Pocket Guide to Table Tennis Tactics – David Fairholm (Bell & Hyman)
Play the game Table Tennis – Donald Parker/David Hewitt (Wardlock)
Top Class Table Tennis – Jill Hammersley/Donald Parker (E P Publishing)
Technical Unit for Sport: Data Sheet 42 (Sports Council)
What is the Sports Council? Fact sheet (Sports Council)
Table Tennis, the Early Years – Gerald N Gurney (ITTF)
Psyched to Win – Robert Nideffer (Leisure Press)

USEFUL ADDRESSES

The English Table Tennis Association

Queensbury House
 Havelock Road
 Hastings
 East Sussex
 TN34 1HF
 Tel: 01424 722525
 Fax: 01424 422103
 www@etta.co.uk

The ETTA controls and governs all aspects of organised Table Tennis in England.

The English Schools' Table Tennis Association (ESTTA)

Geoff Gardiner (Hon. Secretary)
 36 Froom Street
 Chorley
 Lancashire
 PR6 0AN
 Tel: 01257 264873

The ESTTA organises and promotes schools competitions.

The Scottish Table Tennis Association

Caledonia House
 South Gyle
 Edinburgh
 Scotland
 EH12 9DQ
 Tel: 0131 317 8077
 Fax: 0131 317 8224

The Sports Council

16 Upper Woburn Place
 London
 WC1H 0QP
 Tel: 0207 273 1500
 Fax: 0207 383 5740

The Sports Council is a national government-funded body set up to develop sport in this country. Its main purpose is to encourage people to enjoy the benefits of taking part in sport and physical recreation. Further aims include increasing and improving facility provision, raising standards of sporting performance and the allocation of Government funds to sport in pursuit of these aims.

The Council was established as an independent and executive body by a Royal Charter in 1972 to replace the previous advisory Sports Council. In addition to its Headquarters, there are ten regional offices, which cover England. There are separate Councils for Wales, Scotland and Northern Ireland.

The Central Council for Physical Recreation (CCPR)

Francis House
 Francis Street
 London
 SW1P 1DE
 Tel: 0207 828 3163
 Fax: 0207 630 8820

A non-governmental, voluntary organisation representing the interests of sport and recreation bodies in the promotion of measures to improve and develop sport. The CCPR runs the Community Sports Leaders Award (CSLA) which is considered by many as a good first step on the coaching ladder and is often used with senior students who are in the latter stages of secondary education.

The National Coaching Foundation (NCF)

114 Cardigan Road
 Leeds
 Yorkshire
 LS6 3BJ
 Tel: 0113 2744802
 Fax: 0113 2755019

The NCF promotes coaching and coaches at all levels by providing education and resources concerning common areas of sport.

The Women's Sports Foundation (WSF)

Wesley House
 4 Wild Court
 London
 WC2B 5AU
 Tel: 0208 697 5370

The WSF is committed to improving and promoting opportunities for women in sport at every level.

OPPORTUNITIES FOR YOUNG PEOPLE IN TABLE TENNIS

Join a Table Tennis Club – Local club contacts should be available in the school/town library or the local authority recreation department (often based at Council offices). Alternatively contact ETTA 01424 722525.

Coaching – Qualified coaches have regular sessions to help players of all abilities improve their game. Centres for Excellence cater for elite players in every region.

Competitions – Many and varied including local schools team and individual events and local Woolwich Junior Leagues. Higher up the ladder, county championships Woolwich Junior British League and many open tournaments are staged throughout the country.

Representative honours – Players can aspire to representing their club, town, county and country.

Top Class Table Tennis – A variety of exciting spectator events, including England international matches, are staged in towns and cities all over the country. School parties are encouraged – often at concessionary rates.

OPPORTUNITIES AND RESOURCES AVAILABLE FROM ETTA

Join a Table Tennis Club and School-Club Link Scheme – details on request

Woolwich Junior League – details on request

Promotional Posters

Grant aid – details on request

Dunlop Skills Awards

Coaching videos 1 Learning to play the game
 2 Advanced stroke play